

kahyaoglu

paslanmaz çelik san.tic.ltd.şti.

ÜRÜN KATALOĞU PRODUCTS CATALOGUE



since 1997
KAHYAOGLU
MARKET
ONLINE SATIŞ

WWW.KAHYAOGIUPASLANMAZ.COM
WWW.KAHYAOGIUPASLANMAZ.NET
WWW.OLIVINOX.COM

Firmamız 1997 yılında Balıkesir'in Ayvalık ilçesinde kurulmuş olup; 2000 metrekare kapalı alanda hizmet veren sektörün en eski firmalarından biridir. Kurucumuz Celal KAHYAOĞLU gıda sektöründe uzun yıllar boyunca edindiği deneyim ve bilgi birikimi ile yüksek teknoloji ve imalat konusunda uzmanlaşmış bir ekiple birleştirilerek gıda ve kimya sektörünün her alanına hitap eden paslanmaz çelik imalatlar yapmaya başlamıştır.

Celal KAHYAOĞLU alanında Türkiye'nin önde gelen firmaları Komili Yağ ve sabun sanayi, Anagıda-Kırlangıç, Tariş, Marmara Birlik, Başer Gıda San, Yudum Yağ Sanayi, Rast gıda, Zeryağ, Tarım Kredi Kooperatifleri, Güneydoğu Birlik, Elit Gıda Aş., Verde, Sunar Yağ San., Oruçoğlu yağ san. ve bunun gibi birçok firmanın da bulunduğu yurtiçi ve yurtdışındaki büyüklü küçüklü birçok fabrikanın danışmanlık, proje, imalat ve montaj aşamalarına imzasını atmış, konusunda yetkin bir iş insanıdır. Ayrıca yurtiçi ve yurtdışında rafine, gliserin, biodizel, sabun tesisi, soğutma hatları ve arıtma tesisleri gibi birçok tesise danışmanlık, proje, imalat ve montaj hizmetleri vermiştir.

Başlarda sadece Türkiye'ye hizmet veren firmamız günümüzde K.K.T.C., Yunanistan, Belçika, Polonya, İspanya, Almanya, Tunus, Fas, Cezayir, Gürcistan, Ermenistan, Azerbaycan, Suriye, Ürdün, Lübnan, Suudi Arabistan, Irak, İran gibi ülkelere Türk ürünleri göndermenin haklı gururunu yaşamaktadır.

Firmamızın önceleri yurtdışından ithal edilen her türlü proses tankları, Kieselguhr filtreler, plakalı filtreler, fulvar, otomatik ve yarı otomatik dolum makineleri başta olmak üzere pek çok ürünün Türkiye'deki ilk yerli üretimini gerçekleştirerek gıda ve kimya sektörünün hizmetine sunmuştur. Ayrıca firmamız yoğun ve akışkan sıvılar için her türlü gıda ekipmanları imal etmektedir. İmalatımızda kullanılan her türlü parça ve malzeme insan sağlığı ve doğaya zararlı olmamasına özel bir dikkat göstererek titizlikle seçilmiş olup tamamı AISI normlarına uygun 304 ve 316 standartlarında sertifikalı paslanmaz çelikten imal edilmektedir.

Hizmet verdiğimiz sektörler arasında başta zeytinyağı, zeytin, şarap, sirke, pekmez, rakı, bira olmak üzere süt, salça, reçel, bal, çikolata gibi gıda sektörleri ve biodizel, gliserin, sabun, kolonya, temizlik ürünleri gibi kimya ve kozmetik sektörleri bulunmaktadır. Bunların yanında küçük işletmeleri desteklemek amacıyla ekonomik yarı otomatik ve manuel makineler üretmek sektörün gelişmesine destek vermekteyiz. Ev kullanımı için dizayn ettiğimiz küçük ölçekli stok kaplarıyla her kesime hizmet sunmaya çalışmaktayız.

Firmamızın diğer önemli bir özelliği de firmaların ihtiyacı olan ancak bulamadıkları yaptıramadıkları ürünleri dizayn ederek geliştirilerek firmalara destek vermesidir.

Kurulduğu günden bu yana AR-GE çalışmalarına büyük önem veren firmamız 2010 yılından beri Karasuyu en ekonomik şekilde çevreye zarar vermeyecek hale dönüştürerek, sıcak buhar (ısı enerjisi), gübre ve kuru pürine şeklinde geri kazandırma konusunda yaptığı çalışmalardan olumlu neticeler alarak tasarladığı sistem için patent çalışması başlatmış olup en kısa sürede kontinü sahiplerinin hizmetine sunmayı hedeflemektedir.

Siz değerli müşterilerimize en iyi şekilde hizmet vermek arzusundayız. Sizleri de birlikte gelişerek büyümeye davet ediyoruz

Our company was established in 1997 in Ayvalık district of Balıkesir; It is one of the oldest companies in the sector, serving in a 2000 square meter closed area. Our founder Celal KAHYAOĞLU has combined his experience and knowledge gained in the food sector for many years with a team specialized in high technology and manufacturing and started to produce stainless steel products that appeal to all areas of the food and chemical industry.

Celal KAHYAOĞLU is a competent businessman, having his signature on Projecting, production and installation of complete facilities of well-established factories leading in their fields, likewise Anagıda-Kırlangıç, Tariş, Marmara Birlik, Başer Gıda, Yudum Yan San, Rast Gıda, Zeryağ, Tarım Kredi Kooperatifleri, Güneydoğu Birlik, Elit Gıda, Verde, Sunar Yağ, Oruçoğlu...etc. In addition, he has provided consultancy, project, manufacturing and assembly services to many facilities such as refining, glycerin, biodiesel, soap plant, cooling lines and treatment plants in Turkey and abroad.

At the very beginning, our company serviced locally and domestically, but today we have the pride for serving more than 40 countries, such as Cyprus, Greece, Belgium, Poland, Spain, Germany, Tunisia, Morocco, Algeria, Georgia, Armenia, Azerbaijan, Syria, Jordan, Lebanon, Saudi Arabia, Iraq and Iran.

We are the initial factory in Turkey that developing and producing domestically mainly every kind of process and stock tanks, plated filters, diatomit earth filters, destemmers, filling machines and many other products for food and chemical industry as before they had been imported from foreign countries. Besides our company is producing every kind of dense and fluid food machine at the moment. Every material and piece of the machines are preferred as harmless to human health and nature. All main parts are made of European certified stainless steel AISI 304 and AISI 316.

Among the sectors we serve are food sectors such as olive oil, olive, wine, vinegar, molasses, raki, beer, milk, tomato paste, jam, honey, chocolate and chemistry and cosmetics sectors such as biodiesel, glycerin, soap, cologne, cleaning products. In addition to these, we support the development of the sector by producing economical semi-automatic and manual machines to support small businesses. We try to serve every segment of society with small-scale stock containers designed for home use.

Our company has the mission of supporting companies by designing and developing products that companies need but cannot find.

Our company, which gives great importance to R & D studies since the establishment, has been working on a patent for the system designed by taking positive results from the works we has done in the form of hot steam (heat energy), fertilizer and dry pomace by transforming the Blackwater into a state that will not harm the environment in the most economical way since 2010, and we aim to put it into the service of its continuous owners as soon as possible.

We wish to serve our valued customers in the best way possible. We invite you to grow together

• KONTİNÜ SİSTEM ZEYTİNYAĞI EKSTRAKSİYON HATLARI / CONTINUOUS SYSTEM OLIVE OIL EXTRACTION LINES.....	3 – 7
• BESLEME VE DOZAJLAMA MAKİNELERİ / FEEDING AND DOSAGING MACHINES.....	8
• SAP AYIRMA VE PATLATMA MAKİNELERİ / DESTEMMERS AND CRUSHERS.....	9 – 11
• MEYVE PARÇALAMA MAKİNELERİ / FRUIT CRUSHERS.....	11
• MONOPOMPLAR / MONOPUMPS.....	11
• PRESLER / PRESSES.....	12 – 14
• IDRO SERİSİ BALON PRESLER / IDRO SERIES WATER PRESSES.....	15
• PNÖMATİK BALON PRESLER / PNEUMATIC PRESSES.....	16
• KATI MEYVE PRESLERİ / FRUIT PRESSES.....	16
• YATAY VE DİKEY TOPRAKLI FİLTRELER / HORIZONTAL AND VERTICAL EARTH FILTERS.....	17
• TOPRAKLI FİLTRE SARF MALZEMELERİ / EARTH FILTER CONSUMABLES.....	18
• TOPRAKLI FİLTRE TEL YENİLEME / EARTH FILTER RENOVATION.....	18
• TAMBUR FİLTRELER / ROTARY DRUM FILTERS.....	18
• TORBALI GAF TİPİ FİLTRELER / BAG FILTERS.....	19
• PLAKALI KAĞIT FİLTRELER / PRESS PANEL FILTERS.....	20
• MAMUL DOLUM MAKİNELERİ / PRODUCT FILLING MACHINES.....	21 – 23
• CLEVER SİSTEM DOLUM PAKETLEME HATTI / CLEVER SYSTEM TIN AND BOTTLE FILLING AND PACKAGING LINE.....	24 – 25
• PLASTİK KAPAK KAPAMA MAKİNELERİ / PLASTIC CAP CLOSER.....	25
• MANUEL MANTAR KAPAMA MAKİNELERİ / MANUAL CORKING MACHINES.....	25
• YARI OTOMATİK MANTAR KAPAMA MAKİNELERİ / SEMI-AUTOMATIC CORKING MACHINES.....	26
• MANUEL KAPAK SIVAMA MAKİNELERİ / MANUAL CAP CLOSER.....	27
• OTOMATİK KAPAK SIVAMA MAKİNELERİ / AUTOMATIC ALUMINIUM CAP CLOSER.....	27
• YARI OTOMATİK KAPAK SIVAMA MAKİNELERİ / SEMI-AUTOMATIC CAP CLOSERS.....	28 – 29
• ŞİŞE YIKAMA MAKİNELERİ / BOTTLE WASHING MACHINES.....	29
• MANUEL KAPŞONLAMA MAKİNELERİ / MANUAL HOOD SHRINKERS.....	30
• YARI OTOMATİK KAPŞONLAMA MAKİNELERİ / SEMI-AUTOMATIC HOOD SHRINKERS.....	30
• KONVEYÖRLER / CONVEYORS.....	31
• EMNİYET BANDI BÜZME TÜNELLERİ / SAFETY SEAL SHRINK TUNNELS.....	31
• MANUEL ETİKETLEME MAKİNELERİ / MANUAL LABELING MACHINES.....	31
• YARI OTOMATİK ETİKETLEME MAKİNELERİ / SEMI-AUTOMATIC LABELING MACHINES.....	32
• EKONOMİK OTOMATİK ETİKETLEME MAKİNELERİ / ECONOMICAL AUTOMATIC LABELING MACHINES.....	33
• OTOMATİK ETİKETLEME MAKİNELERİ / AUTOMATIC LABELING MACHINES.....	33
• MÜREKKEP PÜSKÜRTMELİ KONVEYÖR TİPİ YAZICILAR / INKJET PRINTERS.....	33
• KALEM TİPİ YAZICILAR / PEN PRINTERS.....	34
• KAŞE VE TABANCA TİPİ YAZICILAR / STAMP PRINTERS.....	34
• ŞRINK PAKETLEME TÜNELLERİ / SHRINK PACKING TUNNELS.....	34
• ÇALIŞMA TEZGAHLARI / WORK BENCHES.....	34
• GÜĞÜMLER / DRUMS.....	37
• DÜZ DİPLİ (AYAKSIZ) LANCALAR / FLAT BOTTOM SIMPLE TANKS WITHOUT LEGS.....	38
• AYAKLI LANCALAR / SIMPLE STORAGE TANKS WITH LEGS.....	39
• MAMUL TAŞIMA TANKLARI / PRODUCT CARRIAGE TANKS.....	40
• EĞİK DİPLİ YÜZER KAPAKLI FERMANTASYON VE DEPOLAMA TANKLARI / FERMANTATION TANKS WITH INCLINED BOTTOM AND FLOATING LIDS.....	41
• YÜZER KAPAKLI LANCALAR / SIMPLE TANKS WITH FLOATING LID.....	42
• DÜZ DİPLİ AYAKSIZ STOK TANKLARI / VERTICAL STOCK TANKS WITH FLAT BOTTOM.....	43
• KONİK DİPLİ AYAKLI STOK TANKLARI / STOCK TANKS WITH LEGS AND CONICAL BOTTOM.....	44
• EĞİK DİPLİ FERMANTASYON TANKLARI / FERMANTATION TANKS WITH LEGS AND INCLINED BOTTOM.....	47
• PROSES TANKLARI / PROCESS TANKS.....	48 – 50
• YATIK TİP STOK TANKLARI / HORIZONTAL STORAGE TANKS.....	51
• TANK AKSESUARLARI / TANK ACCESSORIES.....	52 – 53
• AZOT VE ARGON ENJEKSİYON SİSTEMLERİ / NITROGEN AND ARGON INJECTION SYSTEMS.....	54
• SIVI AKTARMA POMPARLARI / LIQUID TRANSFER PUMPS.....	55 – 56
• TAM HAT BAL İŞLEME TESİSİ / FULL LINE HONEY PROCESS PLANT.....	59

Olivinox 500 GOLD & Olivinox 300 TREASURE & Olivinox 100

KONTİNÜ SİSTEM ZEYTİNYAĞI EKSTRAKSİYON HATLARI
CONTINUOUS SYSTEM OLIVE OIL EXTRACTION LINES



SOĞUK SIKIM
COLD EXTRACTION

Olivinox 500 GOLD

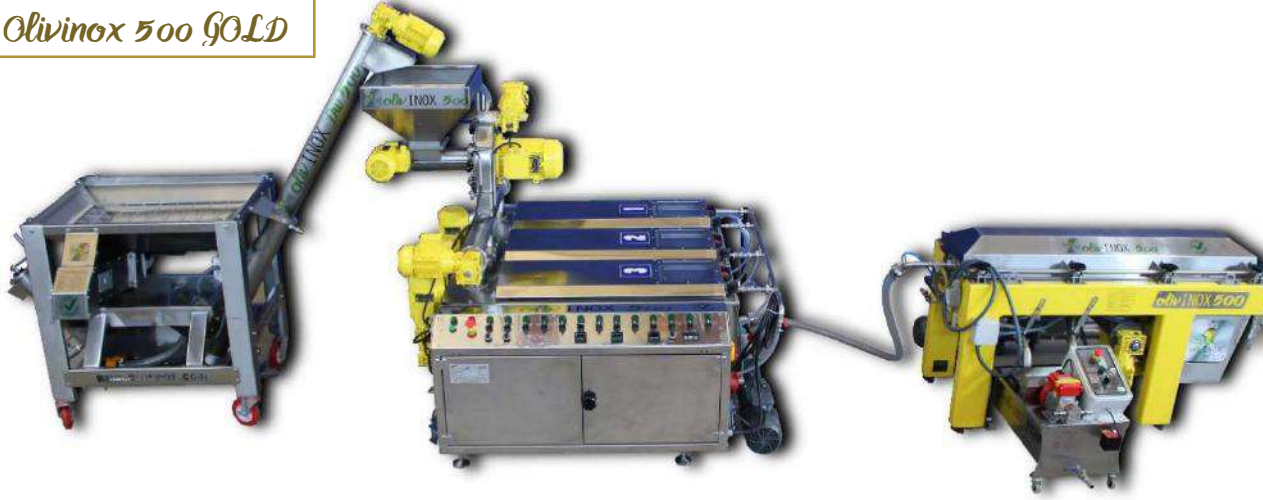

- Soğuk zeytinyağı ekstraksiyon hattımızın her aşamasında bulunan frekans konvertörleri ile kalite her zaman kontrol altında
- Mükemmel yıkama, yaprak ve taş alma
- Maksimum kırma verimi için X210CR12 kırıcı bıçakları
- Her malaksördeki 2 kw rezistanslar ve 0,07kw sirkülasyon pompaları ile kontrol panelinden istenen hamur sıcaklığı ayarlanabilir.
- Her malaksörde seviye sensörü
- Geniş ve contalı malaksör kapakları
- AISI 316 kalite paslanmaz çelikten imal 4100 RPM dekantör
- AISI 304 kalite dekantör kapakları
- Kaba filtrelili yağ toplama arabası ve pompası.
- Her aşamada yıkama suyu hattı
- Tekerlekli üretilebilir (Opsiyonel)
- Nitrojen veya argon gazı uyumlu malaksörler (Opsiyonel)
- Malaksörler vakum sistemli üretilebilir. (Opsiyonel)

Olivinox 300 TREASURE



- Cold extraction line for perfect olive oil has speed adjustment by frequency converters at every step. So quality is always under control.
- Perfect washing with destoner and deleafer.
- Maximum crushing quality with crusher blades made of X210CR12.
- 2kw heater and 0,07kw circulation pump on each malaxer can be control from the control panel and the desired temperature can be set.
- Each malaxer has a level sensor.
- Large malaxer lids with gasket.
- 4100 RPM decanter made of AISI 316 SS.
- AISI 304 SS decanter covers.
- Oil collecting trolley with mesh screen for pre filtration.
- Washing water pipeline at every step.
- Can be produced on wheels. (Optional)
- Malaxers can be produced with nitrogen or argon system. (Optional)
- Malaxers can be produced with vacuum system. (Optional)

Olivinox 300 TREASURE

DW 300	Güç/Power	Kapasite/Capacity
Yaprak alma + Yıkama Deleafing + Washing	Total 0,86 kw	
Fan besleme helezonu Fan feeding screw	0,12 kw	400 kg/h Max
Fan	0,37 kw	
KR 3 M Besleme Helezonu KR 3 M Feeding Screw	0,37 kw	400 kg/h Max
Ölçüler / Dimensions	H:2100 mm / L:1630 mm / W:1280 mm	
Hazne Yüksekliđi / Bunker Height	1150mm	
Su ihtiyacı Water Need	En az 350 lt/sa. temiz ve yumuřak su Min. 350 lt/h clean and soft water	

KR 2 M	Güç/Power	Kapasite/Capacity
Sıyırıcı Kırıcı + 2 x 150 lt. Malaksör Crusher with stearer + Malaxers	Total 9,73 kw	2 x 150 lt
Kırıcı Besleme Helezonu Crusher Feeding Screw	0,25 kw	600 kg/h max
KR 500 Kırıcı / Crusher	3,0 kw +0,25 kw	600 kg/h max
Malaksör Besleme Helezonu Malaxer Feeding Screw	0,25 kw	600 kg/h max
M 150 Malaksör M 150 Malaxer	0,37 kw x 2 adet 0,37 kw x 2 pcs.	150 lt x 2 adet 150 lt x 2 pcs.
Malaksör Rezistansı Malaxer Heaters	2,0 kw x 2 pcs	
Sirkülasyon Pompası Circulation Pump	0,07 kw x 2 pcs	
Hamur Monopompu / Paste Pump	1,1 kw Monopump	400 lt/h max
Ölçüler / Dimensions	H:1550 mm / L:2080 mm / W:1290mm	

D 300	Güç/Power	Kapasite/Capacity
Dekantör /Decanter	Total 5,35 kw	
Dekantör / Decanter	4,0 kw @ 4100 rpm	400 kg/h max
Atık monopompu / Pomace Pump	1,1kw	550 lt/h max
Ölçüler / Dimensions	H:1020mm / L:1700mm / W:610mm	

YTHP	Güç/Power	Kapasite/Capacity
Toplam Güç / Total Power	0,44 kw	Max. 900 lt/h
Toplam Ölçüler / Total Dimensions	H:600 mm / L:800 mm / W:500 mm	

Olivinox 300 Treasure set	Güç/Power	Kapasite/Capacity
Toplam Güç / Total Power	16,38 kw 380V TF	Max. 400 kg/h max
Toplam Ölçüler / Total Dimensions	H:2100 mm / L:5850 mm / W:1290 mm	

Olivinox 500 GOLD

DW 500	Güç/Power	Kapasite/Capacity
Yaprak alma + Yıkama + Tař alma Deleafing + Washing + Destoning	Total 1,11 kw	
Fan besleme helezonu Fan feeding screw	0,12 kw	600 kg/h max
Fan	0,37 kw	
Dalgıç Pompa Water Pump	0,25 kw	
KR 3 M Besleme Helezonu KR 3 M Feeding Screw	0,37 kw	600 kg/h max
Ölçüler / Dimensions	H:2100 mm / L:1680 mm / W:1280 mm	
Hazne Yüksekliđi / Bunker Height	1150 mm	
Su ihtiyacı Water Need	En az 600 lt/sa temiz ve yumuřak su Min. 600 lt/h clean and soft water	

KR 3 M	Güç/Power	Kapasite/Capacity
Sıyırıcı Kırıcı + 3 x 150 lt. Malaksör Crusher with stearer + Malaxers	Total 12,17 kw	3 x 150 lt.
Kırıcı Besleme Helezonu Crusher Feeding Screw	0,25 kw	600 kg/h max
KR 500 Kırıcı / Crusher	3,0 kw + 0,25 kw	600 kg/h max
Malaksör Besleme Helezonu Malaxer Feeding Screw	0,25 kw	600 kg/h max
M 150 Malaksör M 150 Malaxer	0,37 kw x 3 pcs	150 lt x 3 pcs
Malaksör Rezistansı Malaxer Heater	2,0 kw x 3 pcs	
Sirkülasyon Pompası Circulation Pump	0,07 kw x3 pcs	
Hamur Monopompu / Paste Pump	1,1 kw monopump	600 lt/h max
Ölçüler / Dimensions	H:1550 mm / L:2080 mm / W:1720mm	

D 500	Güç/Power	Kapasite/Capacity
Dekantör /Decanter	5,35 kw	
Dekantör / Decanter	4,0 kw @ 4100 rpm	600 kg/h max
Bořaltma helezonu / Emptying screw	0,25 kw	750 kg/h max
Atık monopompu / Pomace Pump	1,1 kw	750 lt/h max
Ölçüler / Dimensions	H:1020 mm / L:1850 mm / W:610 mm	

YTHP	Güç/Power	Kapasite/Capacity
Toplam Güç / Total Power	0,44 kw	Max. 900 lt/h max
Toplam Ölçüler / Total Dimensions	H:600 mm / L:800 mm / W:500 mm	

Olivinox 500 Gold set	Güç/Power	Kapasite/Capacity
Toplam Hat Gücü / Total Line Power	19,07 kw 380V TP	Max. 600 kg/h
Top. Hat Ölçüleri / Total Line Dimensions	H:2100 mm / L:6100 mm / W:1720 mm	

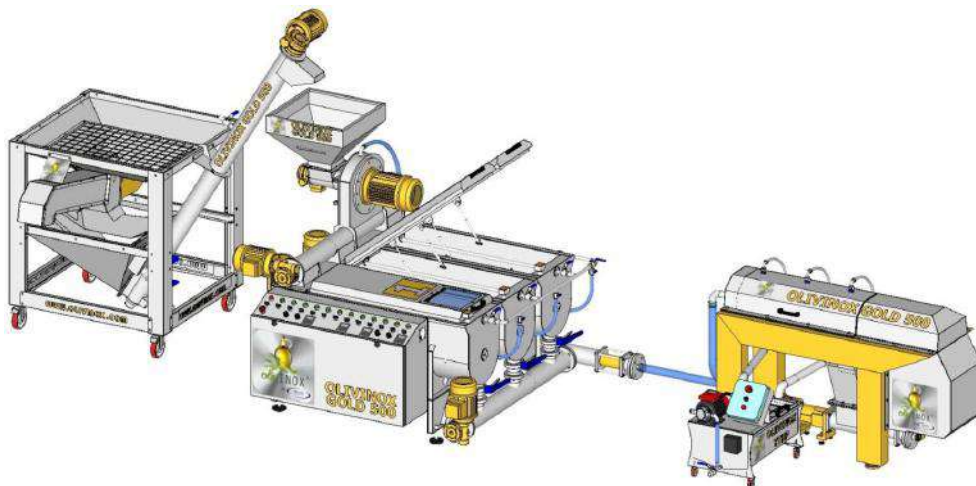

Olivinox 500 GOLD



Olivinox 500 GOLD



Olivinox 300 TREASURE

Olivinox 100



SOĞUK SIKIM
COLD EXTRACTION



Olivinox 100 Set

DW 300	Güç/Power	Kapasite/Capacity
Yaprak alma + Yıkama Deleafing + Washing	Total 0,86 kw	
Fan besleme helezonu Fan feeding screw	0,12 kw	350 kg/h Max
Fan	0,37 kw	
KR 3 M Besleme Helezonu KR 3 M Feeding Screw	0,37 kw	400 kg/h Max
Ölçüler / Dimensions	H:2100 mm / L:1630 mm / W:1280 mm	
Hazne Yüksekliği / Bunker Height	1150mm	
Su ihtiyacı Water Need	En az 100 lt/sa. temiz ve yumuşak su Min. 100 lt/h clean and soft water	

KR 1 M	Güç/Power	Kapasite/Capacity
Sıyırıcı Kırıcı + 1 x 150 lt Malaksör Crusher with stealer + Malaxers	Total 5,007 kw	150 lt
Kırıcı Besleme Helezonu Crusher Feeding Screw	0,18 kw	150 kg/h max
KR 100 Kırıcı / Crusher	2,2 kw	150 kg/h max
M 100 Malaksör	0,37 kw x 1 adet	150 lt x 1 adet
M 100 Malaxer	0,37 kw x 1 pcs.	150 lt x 1 pcs.
Malaksör Rezistansı Malaxer Heaters	2,0 kw x 1 pcs	
Sirkülasyon Pompası Circulation Pump	0,07 kw x 1 pcs	
Oval Pompa / Oval Pump	0,25 kw	400 lt/h max
Ölçüler / Dimensions	H: 1020 mm / L: 1700 mm / W: 610 mm	

D 100	Güç/Power	Kapasite/Capacity
Dekantör /Decanter	Total 2,57 kw	
Dekantör / Decanter	2,2 kw @ 4100 rpm	400 kg/h max
Atık monpompu / Pomace Pump	0,37 kw	550 lt/h max
Ölçüler / Dimensions	H:1020mm / L:1700mm / W:610mm	

YTHP	Güç/Power	Kapasite/Capacity
Toplam Güç / Total Power	0,44 kw	Max. 900 lt/h
Toplam Ölçüler / Total Dimensions	H:600 mm / L:800 mm / W:500 mm	

Olivinox 100 Set	Güç/Power	Kapasite/Capacity
Toplam Güç / Total Power	8,877 kw 380V TF	Max. 100 kg/h max
Toplam Ölçüler / Total Dimensions	H:2100 mm / L:5850 mm / W:1290 mm	

OLIVINOX 100 mükemmel kalitede zeytinyağı üreten hepsi bir arada ekstraksiyon hattıdır

- Soğuk sıkım için her etabında frekans konvertörü ile hız ayarı bulunmaktadır. Böylece kalite her zaman kontrol altında tutulur.
- Yaprak alma makinesi ile mükemmel yıkama.
- X210CR12 malzemeden imal bıçaklar azami parçalama sağlar.
- 2 kW ısıtıcı ve 0,12 kW sirkülasyon pompası istenilen sıcaklığı ayarlamak ve kontrol edebilmek için kontrol panosundan ayarlanabilir.
- Malaksörde seviye sensörü mevcuttur.
- Contalı geniş malaksördür.
- Dekantör AISI316 paslanmaz çelikten imaldir ve 4200 RPM'de çalışmaktadır.
- Dekantör kapağı AISI 304 paslanmaz çelikten.
- Ön filtrasyon yapabilen ve tel izgaralı yağ toplama arabası.
- Her etapta yıkama suyu için boru tesisatı mevcuttur.
- Tekerlekli, mobildir.
- Malaksör Azot/Argon sistemli olarak üretilebilir. (Opsiyonel)
- Malaksör vakum sistemli olarak üretilebilir. (Opsiyonel)

OLIVINOX 100 is an all in one extraction line for producing perfect olive oil

- The system contains frequency converter on every stage for acquiring cold extraction. Thus, quality is kept under control.
- Perfect washing with deleafing machine.
- Maximum crushing with X210CR12 material blades.
- Within the control panel the desired temperature can be arranged and kept under control with
- 2 kW heater and 0,12 kW circulation pump.
- Malaxer contains level sensor.
- Large and sealed malaxer.
- Decanter is produced with AISI316 stainless steel and works with 4200 RPM.
- Decanter cover is made up of AISI 304 stainless steel.
- Oil collection cart with wired rack and pre-filtration.
- Piping for washing water on every stage.
- Wheeled and mobile.
- Malaxer can be produced with Nitrogen / Argon injection system. (Optional)
- Malaxer can be produced with vacuum system. (Optional)

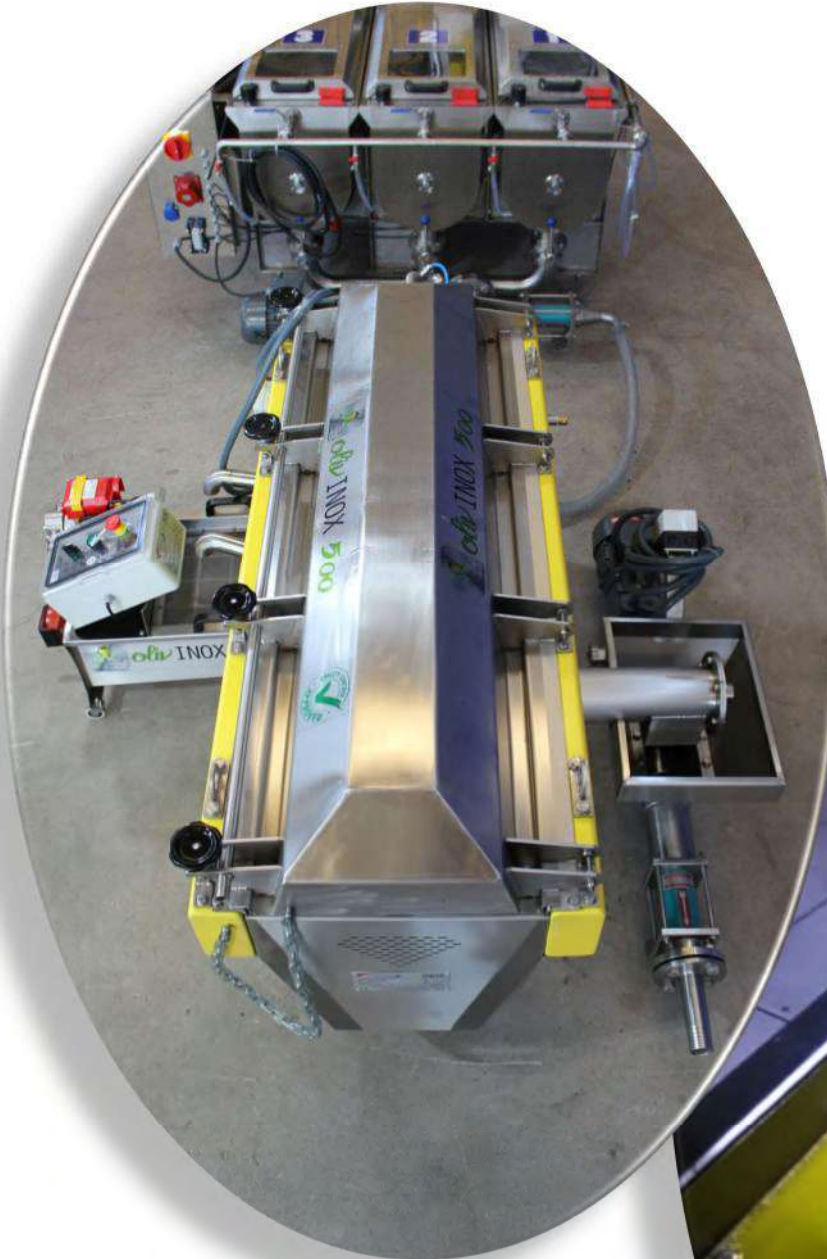

BESLEME VE DOZAJLAMA MAKİNELERİ FEEDING AND DOSAGE MACHINES

VİBRASYONLU DOZAJLAMA MASASI
VİBRASYONLU DOZAJLAMA MASASI-2
TİTREŞİMLİ AYIRMA MASASI
KONVEYÖR BANTLI SEÇME BANDI
ELEVATÖR



ELEVATÖR / ELEVATOR

* Çeşitli varyasyonlar ile üretilmektedir
* Various dimensions

Genişlik (mm)	200	250	300	400	
Uzunluk (mm)	2000	2500	3000	4000	5000

KONVEYÖR SEÇME BANDI SORTING CONVEYOR BAND

* Çeşitli varyasyonlar ile üretilmektedir
* Various dimensions

Genişlik (mm)	600	800		
Uzunluk (mm)	2500	3000	4000	5000



BESLEME VE DOZAJLAMA MAKİNELERİ FEEDING AND DOSAGE MACHINES

TDV1 / TSV / TS800 / BELT



TS800 – VİBRASYONLU AYIRMA MASASI
TS800 – VIBRATING SORTING TABLE

BELT – ELEVATÖR BANT
BELT – BELT ELEVATOR



TSV – VİBRASYONLU DOZAJLAMA MASASI
TSV – VIBRATING DOSAGE TABLE

TDV1 – VİBRASYONLU DOZAJLAMA MASASI-2
TDV1 – VIBRATING DOSAGE TABLE-2

ZEYTİN YAPRAĞI AYIKLAMA VE KALİBRASYON MAKİNESİ OLIVE DELEAFER AND CALIBRATION MACHINE

E5+1 / E7+1



ÜZÜM SAP AYIRMA VE PATLATMA GRAPE DESTEMMER AND CRUSHERS

MANUEL VE MOTORLU MASA ÜSTÜ MODELLER
MANUAL AND DESKTOP MODELS

MEYVE SUYU
ŞİRKE
ŞARAP
PEKMEZ

FRUIT JUICE
VINEGAR
WINE
MOLASSES



MINİ MANUEL
MINI MANUAL



MINI MOTORLU INOX
MINI MOTOR INOX



BABY MANUEL
BABY MANUAL



BABY MOTORLU INOX
BABY MOTOR INOX



BABY MOTORLU
BABY MOTOR



BABY MOTORLU INOX
BABY MOTOR INOX



FAMILY MOTORLU
FAMILY MOTOR



STAND
BENCH

ÜZÜM SAP AYIRMA VE PATLATMA GRAPE DESTEMMER AND CRUSHERS

ÇİBRE POMPALI MODELLER – WITH POMACE PUMP

MEYVE SUYU
ŞİRKE
ŞARAP
PEKMEZ

FRUIT JUICE
VINEGAR
WINE
MOLASSES



Modello Type Modèle Modelo Modell	Prodüz. Production Production Production Produktion	Potenza Power Puissance Potencia Leistung	Motore Motor Moteur Motor Motor	Ingombro Overall dimension Encombrement Espacio ocupado Masse	Peso Weight Poids Peso Gewicht	Modello Type Modèle Modelo Modell	Prodüz. Production Production Production Produktion	Giri Rpm Tours U/min Rpm	Potenza Power Puissance Potencia Leistung	Tubo Pipe Tuyau Tubo Rohr	Versione Version Version Version Version	Ingombro Overall dimension Encombrement Espacio ocupado Masse	Peso Weight Poids Peso Gewicht		
	Kg/h	HP	V	mm	Kg		Kg/h		V	HP	mm	mm	Kg		
TGOMMA 20	smalto	2200	2	220-380	1180 X 680 X 900 h	94	T15	1500	500	220-380	1.5	50	Smalto	1080X670X870	85
TGOMMA 20	inox	2200	2	220-380	1180 X 680 X 900 h	94	T15I	1500	500	220-380	1.5	50	Inox	1080X670X870	85
TGOMMA 30	smalto	3300	2	220-380	1280 X 680 X 900 h	112	T20	2000	500	220-380	2	50	Smalto	1080X700X910	90
TGOMMA 30	inox	3300	2	220-380	1280 X 680 X 900 h	112	T20I	2000	500	220-380	2	50	Inox	1080X700X910	90
TGOMMA 40	inox	3000-4000	2	220-380	1300 X 700 X 1150	120	T30	3000	600	220-380	2	80	Smalto	1280X700X910	106
TGOMMA 40 M	inox	3000-4000	2	220-380	1300 X 700 X 1150	140	T30I	3000	600	220-380	2	80	Inox	1280X700X910	106



GCI20

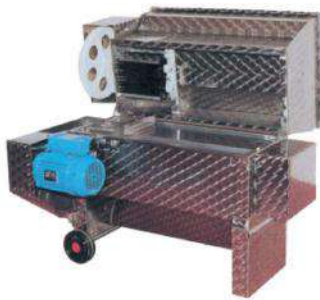

GCI30



T20



T20 INOX



T50 INOX

EMME ÜZÜM SAP AYIKLAMA + PATLATMA
EMME GRAPE DESTEMMER + CRUSHER

Codice Code Code Codigo Code	Modello Type Modelo Modello Modell	Potenza Power Puisance Potencia Leistung	Prod. Production Production Produktion	Motore Motor Moteur Motor Motor	Ingombro Overall dimension Encombremet Espacio ocupado Masse	Velocità battitore Beater speed Vitesse Herisson Velocidad del batidor Verstellgetriebe
		HP	Ton/h	V	mm	Rpm
00005320	EMME 30	2	3-5	380	1700X850X1600	250-500
00005325	EMME 40	2,5	4-8	380	1800X1060X1600	250-500
00005330	EMME 50	3	8-12	380	2100X1060X1600	250-500



KALİTELİ ŞARAP İMALATI İÇİN SAP AYIKLANDIKTAN SONRA ÜZÜM TANELERİ SEÇME BANDINDA SEÇİLMELİ, SONRASINDA PATLATILARAK MONOPOMP İLE AKTARILMALIDIR.

SİRKE
ŞARAP
PEKMEZ

VINEGAR
WINE
MOLASSES



ÜZÜM SAP AYIKLAMA & PATLATMA
GRAPE DESTEMMERS & CRUSHERS

ALPHA 25	2000-2500 KG/H	2 HP
ALPHA 35	3500-4000 KG/H	2 HP
ALPHA 50	4000-5000 KG/H	1,8 HP
ALPHA 70	5000-7000 KG/H	2,2 HP
ALPHA 100	8000-10000 KG/H	2,2 HP
ALPHA 150	12000-15000 KG/H	2,2 HP
ALPHA 200	17000-20000 KG/H	3 HP
EUROPE 2	7000-9000 KG/H	1,8 HP
EUROPE 2TL	7000-9000 KG/H	2,2 HP
EUROPE 3	12000-20000 KG/H	3 HP
EUROPE 3TL	12000-20000 KG/H	3 HP



SİRKE
ŞARAP
PEKMEZ

VINEGAR
WINE
MOLASSES



ALPHA 25



EUROPA 2



EUROPA 2 TL



EUROPA 3



EUROPA 4

TIGER 15 – TIGER 20 – TIGER 25 FULVAR

ÜZÜM SAP AYIKLAMA & PATLATMA & MONOPOMP
GRAPE DESTEMMERS & CRUSHERS & MONOPUMP

TIGER 15	12000-15000 KG/H	7,0 HP
TIGER 20	17000-20000 KG/H	7,5 HP
TIGER 25	20000-25000 KG/H	8,5 HP

SİRKE
ŞARAP
PEKMEZ

VINEGAR
WINE
MOLASSES



TÜRKİYE'NİN
İLK ÜRETİCİSİ

FIRST
PRODUCER
IN TURKEY

MEYVE PARÇALAMA MAKİNELERİ FRUIT BREAKER MACHINES

MINIMIXER30 / MIXER60 / MIX30 / MAXIMIXER100



MINIMIXER30 – 30 LT.
KAPASİTE / CAPACITY



MINIMIXER60 – 60 LT.
KAPASİTE / CAPACITY



MINIMIXER30 – 30 LT.
KAPASİTE / CAPACITY



MINIMIXER100 – 100 LT.
KAPASİTE / CAPACITY

SALÇA MAKİNESİ TOMATO PASTE MACHINE

SALCA – 250 KG/SAAT – KG/HOUR



MONOPOMPLAR / MONOPUMPS

- ÜZÜM SUYU VE ÇİBREYİ 10 METRE YUKARI SAATTE 2, 5, 10 VE 20 TON BASMAK ÜZERE 4 MODEL OLARAK TASARLANMIŞTIR
- MONOPOMPLAR LASTİK STATÖRLÜDÜR
- 1450 RPM MOTOR İLE TAHRİK EDİLMEKTEDİRLER
- DESIGNED IN 4 MODELS TO PUMP 2, 5, 10 AND 20 TONS PER HOUR OF GRAPE JUICE AND GRAIN 10 METERS UP.
- MONOPUMPS HAVE RUBBER STATORS
- DRIVEN AT 1450 RPM

MP 2 MONOPOMP	2 TON/H	2,0 HP
MP 5 MONOPOMP	5 TON/H	3,0 HP
MP 10 MONOPOMP	10 TON/H	4,0 HP
MP 15 MONOPUMP	15 TON/H	4,0 HP
MP 25 MONOPUMP	25 TON/H	5,5 HP



MP5

MEYVE, ÜZÜM PRESLERİ / FRUIT, GRAPE PRESSES



STAR25



TR1

TR3

TR2

TR4



TR35G



TR20G

TR40G

Model	Kapasite/ Capacity lt	Tip / Type	Materyal / Material	Çalışma Şekli / Operation Type	Mobil Özellik / Mobility	Devirme-Mafsals / Knockdown-Joint	Arabalı Kafes / Mobile Cage	Motor Gücü / Motor Power	MF /TF	Hidrolik Piston Çapı / Hydraulic Piston Diameter	Kafes Çapı / Cage Diameter mm
Star 15	6	Manuel / Manual	Ahşap kafes, Demir şase boyalı Wooden cage Enamelled chassis	Vida / Screw	Yok / No	Var / Yes	Yok / No	Yok / No	-	-	150
Star 20	11	Manuel / Manual									200
Star 25	20	Manuel / Manual									250
Star 25 Inox	20	Manuel / Manual	Paslanmaz kafes, Demir şase boyalı Stainless cage Enamelled chassis	Vida / Screw	Yok / No	Var / Yes	Yok / No	Yok / No	-	-	250
TR 30	30	Manuel / Manual	Ahşap kafes, Demir şase boyalı Wooden cage Enamelled chassis	Kontra -Vida / Counter Screw	Yok / No	Yok / Yes	Yok / No	Yok / No	-	-	300
TR 35	50	Manuel / Manual									350
TR 40	70	Manuel / Manual									400
TR 45	85	Manuel / Manual									450
TR 50	130	Manuel / Manual									500
TR 55	170	Manuel / Manual									550
TR 60	220	Manuel / Manual									600
TR 70	330	Manuel / Manual									700
TR 80	500	Manuel / Manual	800								
TR 25 GB Inox	25	Manuel / Manual	Paslanmaz kafes, Paslanmaz şase Stainless cage, Stainless chassis								250
TR 30 GB Inox	30	Manuel / Manual									300
TR 35 GB Inox	50	Manuel / Manual									350
TR 40 GB Inox	70	Manuel / Manual									400
TR 45 GB Inox	85	Manuel / Manual									450
TR 50 GB Inox	130	Manuel / Manual	500								



TIC70



TIC70GI



TIC50I



TIC50IM

Model	Kapasite/ Capacity lt	Tip / Type	Materyal / Material	Çalışma Şekli / Operation Type	Mobil Özellik / Mobility	Devirme-Mafsals / Knockdown-Joint	Arabalı Kafes / Mobile Cage	Motor Gücü / Motor Power	MF /TF	Hidrolik Piston Çapı / Hydraulic Piston Diameter	Kafes Çapı / Cage Diameter mm								
TRG Inox		Manuel / Manual	Paslanmaz Kafes, Demir Boyalı Şase Stainless Cage, Enamelled Chassis	Kontra -Vida / Counter Screw	Yok / No	Yok / No	Yok / No	Yok / No	-	-									
TI 45	85	Hidrolik Manuel Hydraulic Manual	Ahşap Kafes, Demir Şase Boyalı Wooden Cage, Enamelled Chassis	Hidrolik Vida / Hydraulic Screw	Yok / No	Yok / No	Yok / No	Yok / No	-	Pistonsuz / Pistonless	450								
TI 50	130	Hidrolik Manuel Hydraulic Manual									500								
TI 55	170	Hidrolik Manuel Hydraulic Manual									550								
TI 60	220	Hidrolik Manuel Hydraulic Manual									600								
TI 70	330	Hidrolik Manuel Hydraulic Manual									700								
TI 80	500	Hidrolik Manuel Hydraulic Manual									800								
TI 45 GB Inox	85	Hidrolik Manuel Hydraulic Manual	Paslanmaz Kafes, Paslanmaz Şase Stainless Cage, Stainless Chassis	Hidrolik Vida Hydraulic Screw	Var / Yes	Yok / No	Yok / No	Yok / No	-	Pistonsuz / Pistonless	450								
TI 50 GB Inox	130	Hidrolik Manuel Hydraulic Manual									500								
TI 60 GB Inox	220	Hidrolik Manuel Hydraulic Manual									600								
TI 70 GB Inox	330	Hidrolik Manuel Hydraulic Manual									700								
TI 80 GB Inox	500	Hidrolik Manuel Hydraulic Manual									800								
TIC 45	85	Hidrolik Manuel Hydraulic Manual	Ahşap Kafes, Demir Şase Boyalı Wooden Cage, Enamelled Chassis	Hidrolik Vida Hydraulic Screw	Var / Yes	Yok / No	Yok / No	Yok / No	-	Pistonsuz / Pistonless	450								
TIC 50	130										500								
TIC 55	170										550								
TIC 60	220										600								
TIC 70	330										700								
TIC 80	500		800																
TIC 45 GB Inox	85		Paslanmaz Kafes, Paslanmaz Şase Stainless Cage, Stainless Chassis								Hidrolik Vida Hydraulic Screw	Var / Yes	Yok / No	Yok / No	Yok / No	Yok / No	-	Pistonsuz / Pistonless	450
TIC 50 GB Inox	130																		500
TIC 60 GB Inox	220																		600
TIC 70 GB Inox	330																		700
TIC 80 GB Inox	500	800																	
TIC – G Inox			Paslanmaz Kafes, Demir Boyalı Şase Stainless Cage, Enamelled Chassis																



ATOLLO 50E



TIC50I



TIC50M



ATOLLO 100 E1C

Model	Kapasite/ Capacity lt	Tip / Type	Materyal / Material	Çalışma şekli / Operation Type	Mobil Özellik / Mobility	Devirme-Mafsall / Knockdown-Joint	Arabalı Kafes / Mobile Cage	Motor Gücü / Motor Power	MF /TF	Hidrolik Piston Çapı / Hydraulic Piston Diameter	Kafes çapı / Cage Diameter mm
TICUS 40	70	Hidrolik Manuel Hydraulic Manual	Ahşap Kafes, Demir Şase Boyalı Wooden Cage Enamelled Chassis	Hidrolik Hydraulic	Var / Yes	Var / Yes	Yok / No	Yok / No	-	55	400
TICUS 50	130									70	500
TICUS 60	220									90	600
TICUS 70	300									110	650
TICUS 40 Inox	70	Hidrolik Manuel Hydraulic Manual	Paslanmaz Kafes, Demir Şase Boyalı Stainless Cage Enamelled Chassis							55	400
TICUS 50 Inox	130									70	500
TICUS 60 Inox	220									90	600
TICUS 70 Inox	300									110	650
TICUS 40M	70	Hidrolik Motorlu Hydraulic Motor	Ahşap Kafes, Demir Şase Boyalı Wooden Cage Enamelled Chassis					55	400		
TICUS 50M	130							70	500		
TICUS 60M	220							90	600		
TICUS 70M	300							110	650		
TICUS 40 M Inox	70	Hidrolik Motorlu Hydraulic Motor	Paslanmaz Kafes, Demir Şase Boyalı Stainless Cage Enamelled Chassis					55	400		
TICUS 50 M Inox	130							70	500		
TICUS 60 M Inox	220			90	600						
TICUS 70 M Inox	300			110	650						
ATOLLO 50E	127	Hidrolik Motorlu Hydraulic Motor	Ahşap Kafes, Demir Şase Boyalı, Paslanmaz Leğen, Paslanmaz Kafes Kuşakları Wooden Cage Enamelled Chassis Stainless Basin Stainless Cage Belts	1 Adet / Pc	1,36 HP	MF	Ø75 – 15000 KG	500 X 650			
ATOLLO60EGG	212			1 Adet / Pc	1,36 HP	MF	Ø90 – 22250 KG	600 X 750			
ATOLLO60E1C	220			1 Adet / Pc	1,36 HP	MF	Ø90 – 22250 KG	600 X 750			
ATOLLO60E2C	220			2 Adet / Pcs	1,36 HP	MF	Ø90 – 22250 KG	600 X 750			
ATOLLO70E1C	326			1 Adet / Pc	1,5 HP	MF	Ø110 – 33240 KG	700 X 850			
ATOLLO70E2C	330			2 Adet / Pcs	1,5 HP	MF	Ø110 – 33240 KG	700 X 850			
ATOLLO80E1C	477			1 Adet / Pc	1,5 HP	MF	Ø130 – 46400 KG	800 X 950			
ATOLLO80E2C	480			2 Adet / Pcs	1,5 HP	MF	Ø130 – 46400 KG	800 X 950			
ATOLLO 50E	127	Hidrolik Motorlu Hydraulic Motor	Paslanmaz Kafes, Demir Şase Boyalı, Paslanmaz Leğen, Paslanmaz Pres Plakası Stainless Cage, Enamelled Chassis Stainless Basin Stainless Press Plate	1 Adet / Pc	1,36 HP	MF	Ø75 – 15000 KG	500 X 650			
ATOLLO60EGGI	212			1 Adet / Pc	1,36 HP	MF	Ø90 – 22250 KG	600 X 750			
ATOLLO60E1CI	220			1 Adet / Pc	1,36 HP	MF	Ø90 – 22250 KG	600 X 750			
ATOLLO60E2CI	220			2 Adet / Pcs	1,36 HP	MF	Ø90 – 22250 KG	600 X 750			
ATOLLO70E1CI	326			1 Adet / Pc	1,5 HP	MF	Ø110 – 33240 KG	700 X 850			
ATOLLO70E2CI	330			2 Adet / Pcs	1,5 HP	MF	Ø110 – 33240 KG	700 X 850			
ATOLLO80E1CI	477			1 Adet / Pc	1,5 HP	MF	Ø130 – 46400 KG	800 X 950			
ATOLLO80E2CI	480			2 Adet / Pcs	1,5 HP	MF	Ø130 – 46400 KG	800 X 950			
ATOLLO100E1CI	900	Hidrolik Motorlu Hydraulic Motor	Paslanmaz Kafes, Demir Şase Boyalı, Paslanmaz Leğen, Paslanmaz Pres Plakası Stainless Cage, Enamelled Chassis, Stainless Basin, Stainless Press Plate	Hidrolik Hydraulic	Var / Yes	Yok / No	1 Adet / Pc	1,1 – 1,1 HP	TF	Ø180 – 86400 KG	1000 X 1100
ATOLLO100E2CI	900	Hidrolik Motorlu Hydraulic Motor	Paslanmaz Kafes, Demir Şase Boyalı, Paslanmaz Leğen, Paslanmaz Pres Plakası Stainless Cage, Enamelled Chassis, Stainless Basin, Stainless Press Plate	Hidrolik Hydraulic	Var / Yes	Yok / No	2 Adet / Pcs	1,1 – 1,1 HP	TF	Ø180 – 86400 KG	1000 X 1100

İK 330 – MEYVE & ÜZÜM PRESLERİ / FRUIT & GRAPE PRESSES

İK 330
MANUEL HİDROLİK / MANUAL HYDROLIC

İK 330 M
MOTORLU HİDROLİK / MOTORİZED HYDROLIC

PİSTON ÇAPI / PISTON DIA | 700 mm – 220 BAR
CAGE DIA. / KAFES ÇAPI | 700 mm – 220 BAR

AISI 304 SS BASKI PLAKASI / AISI 304 SS
PRESSING PLATE

AISI 304 SS KAFES / AISI 304 SS CAGE

AISI 304 SS TEPSİ / AISI 304 SS BIN

ST52 ŞASE / ST52 CHASIS

TEKERLEKLİ MOBİL / MOBILE ON WHEELS



İK330

İK330M

İDRO SERİSİ BALON PRESLER İDRO SERIES WATER PRESS

HİDROFOR SUYU İLE ÇALIŞAN TİP BALON PRES
BOOSTER OPERATING STAINLESS STEEL WATER
PRESS

PASLANMAZ ÇELİK KAFESLİ VE PASLANMAZ ÇELİK /
BOYALI TAVALI
STAINLESS STEEL CAGE AND STAINLESS STEEL /
ENAMELLED PAN

IDRO 20 / 40 / 80 / 160

IDRO 40SS / 80SS / 160SS / 300SS / 450SS



IDRO20



IDRO40



IDRO40



IDRO160



IDRO80SS



IDRO160S



IDRO450SS

MODEL / MODEL	KAFES BOYUTU / CAGE DIMENSION	KAFES KAPASİTESİ / CAGE CAPACITY	BASINÇ / PRESSURE	GENEL BOYUT / OVERALL DIMENSION	AĞIRLIK / WEIGHT
IDRO20	270 x 390 mm	20	4	540 x 830 mm	15 kg
IDRO40	340 x 480 mm	40	4	650 x 980 mm	20 kg
IDRO80	420 x 580 mm	80	3	700 x 1150 mm	36 kg
IDRO160	540 x 710 mm	160	3	1000 x 1300 mm	70 kg
IDRO40SS	340 x 480 mm	40	4	650 x 980 mm	23 kg
IDRO80SS	420 x 580 mm	80	3	700 x 1150 mm	40 kg
IDRO160SS	540 x 710 mm	160	3	1000 x 1300 mm	75 kg
IDRO300SS	650 x 920 mm	300	3	1100 x 2170 mm	205 kg
IDRO450SS	800 x 900 mm	450	3	1250 x 2400 mm	265 kg

**PNÖMATİK BALON PRESLER
PNEUMATIC PRESSES**

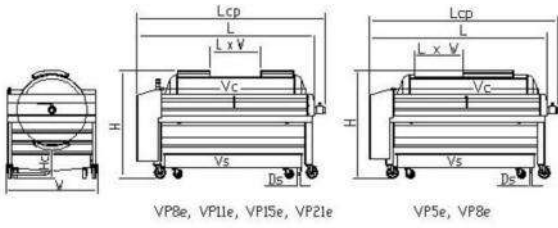

		VP5e	VP8e	VP11e	VP15e	VP21e
Vc	lit	500	800	1100	1500	2100
L x W	mm	570x410	600x410	600x440	900x440	900x440
De		1"	1"	1"	1 1/2"	1 1/2"
Vs	lit	240	370	500	650	750
Lcp	mm	2130	2360	2480	2980	3080
L	mm	1960	2190	2310	2810	2910
W	mm	1040	1140	1270	1270	1460
H	mm	1360	1460	1590	1590	1770
Hc	mm	540	540	500	500	510
Power supply with integrated compressor	kW	3.1	3.1	3.3	3.3	4.7
Dryweight	kg	200	250	430	590	790

		VP5e	VP8e	VP11e	VP15e	VP21e
Whole grapes - loading through door	kg	400	640	880	1200	1680
Fresh destemmed grapes - central loading	kg	1400	2240	3080	4200	5880
Fermented grapes - central loading	kg	1900	3040	4180	5700	7980

**PNÖMATİK BALON PRESLER (PRO)
PNEUMATIC PRESSES (PRO)**

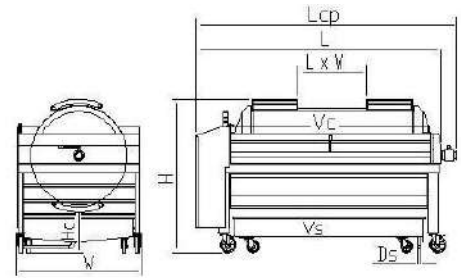

		VP11	VP15	VP21	VP26	VP32	VP44	VP52	VP60
Vc	lit	1100	1300	2100	2800	3200	4400	5200	8000
L x W	mm	680x440	900x440	960x450	960x450	960x450	960x460	960x460	960x460
De		1 1/2"	1 1/2"	1 1/2"	1 1/2"	1 1/2"	1 1/2"	2"	2"
Vs	lit	530	630	730	900	1080	1280	1480	1680
Lcp	mm	2480	2680	2750	3250	3700	3980	4480	4980
L	mm	2310	2810	2580	3080	3580	3790	4290	4790
W	mm	1270	1270	1570	1570	1570	1730	1800	1800
H	mm	1590	1390	1880	1880	1880	2040	2040	2040
Hc	mm	490	490	500	580	580	560	580	560
Power supply with integrated compressor	kW	3	4	5,6	6	6	8,5	10,8	10,8
Dryweight	kg	450	590	790	980	1150	1630	2150	2530

		VP11	VP15	VP21	VP26	VP32	VP44	VP52	VP60
Whole grapes - loading through the door	kg	880	1200	1680	2080	2560	3520	4160	4800
Fresh destemmed grapes - central loading	kg	3080	4200	5880	7280	8960	12320	14500	16500
Fermented grapes - central loading	kg	4180	5700	7980	9880	12160	16720	19760	22800

**KATI MEYVE PRESİ / FRUIT PRESS
KAPASİTE: 1500 KG/SAAT
CAPACITY: 1500 KG/H**



ELMA / ARMUT / AVOKADO / NAR / AYVA
APPLE / PEAR / AVOCADO / POMEGRANATE / QUINCE



YATAY KİESELGUHR (DİATOMİT) FİLTRELER
HORIZONTAL DIATOMECEOUS EARTH FILTERS
2 – 3 – 4 – 5 – 6 m²



TÜRKİYE'NİN
İLK
ÜRETİCİSİ

FIRST
PRODUCER
IN TURKEY

ZEYTİNYAĞI
ŞİRKE
ŞARAP
PEKMEZ
BİRA
ÜZÜM SUYU
MEYVE SUYU

OLIVE OIL
VINEGAR
WINE
MOLASSES
BEER
GRAPE JUICE
FRUIT JUICE



YTF3

MODEL	YAĞ / OIL KAPASİTE (LT/H)	ŞARAP / WINE KAPASİTE (LT/H)
YTF2	500 – 1200	1500 – 3000
YTF3	750 – 1600	2200 – 4500
YTF4	1000 – 2000	3000 – 6000
YTF5	1200 – 2500	3500 – 7000
YTF6	1400 – 3000	4000 – 7500



YTF5



YTF2

DİKEY KİESELGUHR (DİATOMİT) FİLTRELER
VERTICAL DIATOMECEOUS EARTH FILTERS
5 – 6 – 8 – 10 – 12 – 15 – 20 – 30 – 35 m²



TÜRKİYE'NİN
İLK
ÜRETİCİSİ

FIRST
PRODUCER
IN TURKEY

ZEYTİNYAĞI
ŞİRKE
ŞARAP
PEKMEZ
BİRA
ÜZÜM SUYU
MEYVE SUYU

OLIVE OIL
VINEGAR
WINE
MOLASSES
BEER
GRAPE JUICE
FRUIT JUICE

MODEL	YAĞ / OIL KAPASİTE (LT/H)	ŞARAP / WINE KAPASİTE (LT/H)
DTF5	1200 – 250	3500 – 7000
DTF6	1400 – 3000	4000 – 7500
DTF8	1800 – 3500	5000 – 8000
DTF10	2500 – 5000	6500 – 11000
DTF12	3000 – 6000	7500 – 14000
DTF15	3750 – 6500	9300 – 16000
DTF 20	5000 – 8000	12500 – 22000
DTF 30	7500 – 14000	
DTF 35	8750 – 15000	



DTF20



DTF5



DTF10



KIESELGUHR TOPRAĞI F70
KIESELGUHR EARTH F70
PAKETİ 20 KG
PACKAGE 20 KG



BECOCELL 250 SELÜLOZ
BECOCELL 250 CELLULOSE
PAKETİ 20 KG
PACKAGE 20 KG



TÜM KIESELGUHR FİLTRELERİNİN, FİLTRE
TELLERİNİN YENİLENMESİ VEYA YENİDEN
İMALATI
REPLACEMENT OR RE-MANUFACTURING OF ALL
KIESELGUHR FILTERS, FILTER WIRES



TAMBUR FİLTRELER
ROTARY DRUM FILTERS
2,5 – 4 – 6 – 10 m²



SİRKE
MEYVE SUYU
ALKOLLÜ İÇECEKLER

VINEGAR
FRUIT JUICE
ALCOHOLIC DRINKS



TORBALI FİLTRELER BAG FILTERS

GAF 70	1 GÖZ 70CM / 1 HOUSING 70CM
GAF 100	1GÖZ 100CM / 1 HOUSING 100CM
GAF 3X70	1 GÖZ 3 TORBA 70CM / 1 HOUSING 3 TORBA 70CM
GAF 4X70	1 GÖZ 4 TORBA 70CM / 1 HOUSING 4 TORBA 70CM

GAF 70MODULAR SERİ VEYA PARALEL / SERIE OR PARRALLEL
POMPA İLE BERABER SİPARİŞ EDİLEBİLİR / CAN BE ORDERED WITH PUMP

ZEYTİNYAĞI
BİTKİSEL YAĞLAR
SİRKE
BAL
MEYVE SUYU
ALKOLLÜ İÇECEKLER

OLIVE OIL
VEGETAL OIL
VINEGAR
HONEY
FRUIT JUICE
ALCOHOLIC DRINKS

TÜRKİYE'NİN
İLK
ÜRETİCİSİ

FIRST
PRODUCER
IN TURKEY



GAF70P POMPALI TORBALI TİP FİLTRE /
BAG FILTER WITH GAF70P PUMP



GAF100P POMPALI TORBALI TİP FİLTRE /
BAG FILTER WITH GAF-100P PUMP



6 GÖZLÜ GAF FİLTRE /
BAG FILTER WITH 6 CHAMBERS

KAĞIT FİLTRELER (PLAKALI PARLATMA) PRESS PANEL FILTERS FOR POLISHING

KF10P – 40X40 – 10 PLAKA / PLATES POMPALI / WITH PUMP
 KF20P – 40X40 – 20 PLAKA / PLATES POMPALI / WITH PUMP
 KF30P – 40X40 – 30 PLAKA / PLATES POMPALI / WITH PUMP
 KF40P – 40X40 – 40 PLAKA / PLATES POMPALI / WITH PUMP
 KF50P – 40X40 – 50 PLAKA / PLATES POMPALI / WITH PUMP
 KF60P – 40X40 – 60 PLAKA / PLATES POMPALI / WITH PUMP
 KF80P – 40X40 – 80 PLAKA / PLATES POMPALI / WITH PUMP
 KF100P – 40X40 – 100 PLAKA / PLATES POMPALI / WITH PUMP
 * KAPASİTELER MAMULE GÖRE DEĞİŞKENLİK GÖSTEREBİLİR
 * CAPACITY VARIES ACCORDING TO PRODUCT PURITY

MODEL	YAĞ / OIL KAPASİTE (LT/H)	ŞARAP / WINE KAPASİTE (LT/H)
KF10P	200 – 300	1000 – 1200
KF20P	300 – 500	1200 – 2000
KF30P	400 – 750	1800 – 3000
KF40P	600 – 1000	2400 – 4000
KF50P	800 – 1250	3000 – 5000
KF60P	1000 – 1500	4000 – 6000
KF80P	1500 – 1900	5000 – 7000
KF100P	2000 – 2200	6000 – 8000



TÜRKİYE'NİN
İLK
ÜRETİCİSİ

FIRST
PRODUCER
IN TURKEY



KF20P



KF30P



KF40P



KF20+20 P



KF50P



KF60P



KF80P

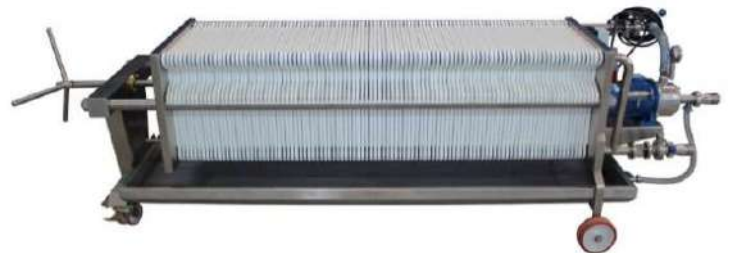

KF100P

YEDEK FİLTRE KAĞITLARI SPARE FILTER PADS

200 X 100 MM
 200 X 200 MM
 400 X 400 MM



400 x 400 MM



200 x 200 MM

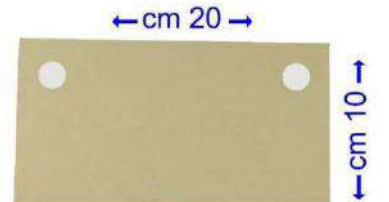

200 x 100 MM

MINI PLAKALI FİLTRELER PRESS PANEL FILTERS

MINI10 – 10X20 – 10 PLAKA / PLATES
MINI6 – 20X20 – 6 PLAKA / PLATES
MINI12 – 20X20 – 12 PLAKA / PLATES
MINI18 – 20X20 – 18 PLAKA / PLATES
MINI25 – 40 X 20 – 25 PLAKA / PLATES
MINI 36 – 20X20 – 36 PLAKA / PLATES
MINI 36 OIL – 20X20 – 36 PLAKA / PLATES

MODEL	MINI 10	MINI 6	MINI 12	MINI 18	MINI 25	MINI 36
YAĞ / OIL KAPASİTE (LT/H)	-	-	-	-	-	200 – 250
ŞARAP / WINE KAPASİTE (LT/H)	80 – 100	120 – 150	150 – 180	180 – 220	1500 – 1750	400 – 500



MINI 10 INOX



MINI 6 INOX



MINI 12 INOX



MINI 18 INOX



MINI 25

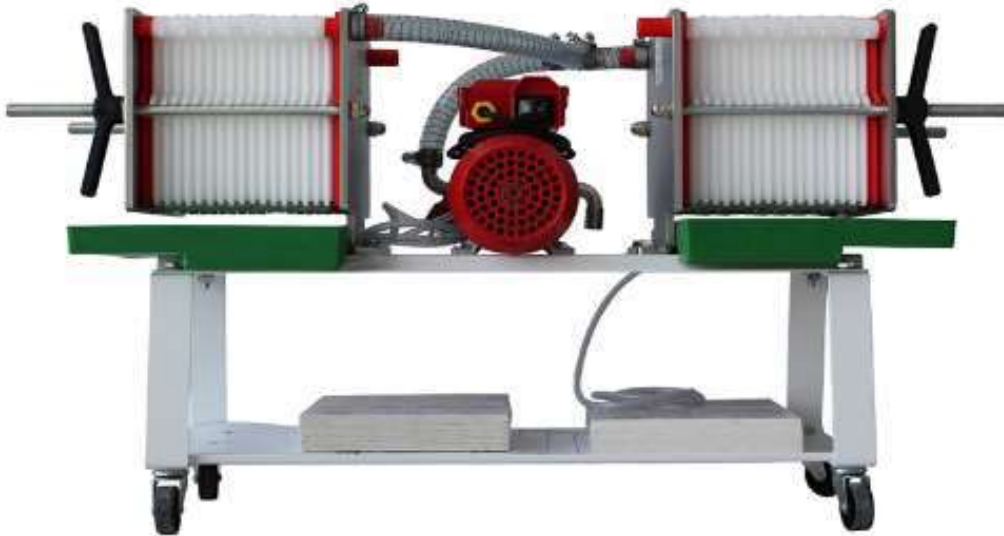

MINI 36 – MINI 36 OIL INOX

MİKROFİLTRASYON MICROFILTRATION

MF10	10"	9,2 LT
MF20	20"	14,2 LT
MF30	30"	19,3 LT



MF10



MF20



MF30



MF30 - 316

BEYAZ VE ROZE ŞARAP KLARİFİKATÖRLERİ WHITE AND ROSE WINE CLARIFIERS

CL12	12.000 LT/SAAT
CL22	22000 LT/SAAT



CL22000



CL12000



MASA ÜSTÜ ŞİŞE DOLUM MAKİNELERİ TABLETOP BOTTLE FILLERS

ENOLMATIC, MBF02, MBF 04
VAKUM ÖZELLİKLİ / WITH VACUUM



ENOLMATIC OIL



ENOLMATIC-YAĞ
ENOLMATIC-OIL
ENOLMATIC-ŞARAP
ENOLMATIC-WINE
ENTOLMATIC-MİNİ ŞİŞE
ENOLMATIC-MIGNON
ENOLMATIC-SÜT
ENOLMATIC-MILK
ENOLMATIC-DOMATES SUYU
ENOLMATIC-TOMATO



MBF02PV



MBF04PV



TÜRKİYE'NİN
İLK
ÜRETİCİSİ

FIRST
PRODUCER
IN TURKEY

YARI OTOMATİK ŞİŞE DOLUM MAKİNELERİ SEMI AUTOMATIC BOTTLE FILLERS

2-4-6-8-12 NOZÜLLÜ / NOZZLES
VAKUMLU / VAKUMSUZ - WITH VACUUM / WITHOUT VACUUM
MİNİ NOZÜLLER İLE MİNİ ŞİŞE DOLUM İMKÂNİ
MINI NOZZLES FOR MINI BOTTLE FILLING



TÜRKİYE'NİN
İLK
ÜRETİCİSİ

FIRST
PRODUCER
IN TURKEY



BF06P



BFPV06F



BF06PV



YARI OTOMATİK ŞİŞE VE TENKE DOLUM MAKİNELERİ SEMI AUTOMATIC BOTTLE AND TIN FILLERS

2 - 4 - 6 ŞİŞE DOLUM NOZÜLLÜ / BOTTLE FILLING NOZZLES
1 - 2 TENKE DOLUM NOZÜLLÜ / TIN FILLING NOZZLES

ŞİŞELER İÇİN SEVİYE ESASLI DOLUM / LEVEL FILLER FOR BOTTLES
TENKELELER İÇİN TARTIM ESASLI DOLUM / WEIGHING FILLER FOR TINS
VAKUMLU / WITH VACUUM
MİNİ NOZÜLLER İLE MİNİ ŞİŞE DOLUM İMKÂNİ
MINI NOZZLES FOR MINI BOTTLE FILLING

T1 - T2
TENKE + ŞİŞE DOLUM
TIN + BOTTLE FILLERS:
T1B4 - T1B6 - T2B4 - T2B6



TÜRKİYE'NİN
İLK
ÜRETİCİSİ

FIRST
PRODUCER
IN TURKEY



T2



T1B6

YARI OTOMATİK TARTIM ESASLI DOLUM MAKİNELERİ SEMI AUTOMATIC WEIGHING FILLERS

MODELLER: FM1 MİNİ – FM1 – FM2
* KÜÇÜK HAVA KOMPRESÖRÜ GEREKTİRİR
* SMALL AIR COMPRESSOR NEEDED



TÜRKİYE'NİN
İLK
ÜRETİCİSİ

FIRST
PRODUCER
IN TURKEY

ZEYTİNYAĞI
BİTKİSEL YAĞLAR
SİRKE
BAL
MEYVE SUYU
ALKOLLÜ İÇECEKLER

OLIVE OIL
VEGETAL OIL
VINEGAR
HONEY
FRUIT JUICE
ALCOHOLIC DRINKS



FM1 MINI



FM2



FM1

VOLUMETRİK DOLUM MAKİNELERİ 5LT YE KADAR
VOLUMETRIC FILLERS UPTO 5 LT

OAAC2 – AAC2 – AAC1
BASINÇLI HAVA GEREKİR – PRESSURISED AIR NEEDED



ZEYTİNYAĞI
BİTKİSEL YAĞLAR
SİRKE

OLIVE OIL
VEGETAL
OIL
VINEGAR



OAAC2



AAC2



AAC1

OTOMATİK ŞİŞE DOLUM VE KAPAK KAPAMA /
MANTARLAMA MAKİNESİ
AUTOMATIC BOTTLE FILLER AND CAPPER /
CORKER

MBL 100 A

YAĞ İÇİN ALUMİNYUM CAPAK SIVAMA MAKİNELİ
FOR OIL WITH SCREW CAPPER



MBL 100 C

ŞARAP İÇİN MANTARLAMA MAKİNELİ
FOR WINE WITH CORKER



500 ŞİŞE/SAAT
500 BOTTLE / HOUR

OPSİYONEL DONANIMLAR:

KTC600 – MBL100 İLE ENTEGRE OTOMATİK ETİKETLEME MAKİNESİ
KTC600 – AUTOMATIC LABELING MACHINE INTEGRATED WITH MBL100

MBL100 İLE ENTEGRE ŞİŞE KONVEYÖRÜ
BOTTLE CONVEYOR INTEGRATED WITH MBL100

MBL100 İLE ENTEGRE OTOMATİK VAKUMLU MANTARLAMA MAKİNESİ
AUTOMATIC CORKING MACHINE WITH VACUUM INTEGRATED WITH
MBL100

MBL100 İLE ENTEGRE DOLUM ÖNCESİ AZOT ENJEKSİYON SİSTEMİ
NITROGEN INJECTION SYSTEM INTEGRATED WITH MBL100

MBL100 İLE ENTEGRE OTOMATİK DAMGALAMA MAKİNESİ
AUTOMATIC STAMPING DEVICE INTEGRATED WITH MBL100



MBL100



KTC600



TENEKE VE ŞİŞE DOLUM SİSTEMİ
TIN AND BOTTLE FILLING SYSTEM



TÜRKİYE'NİN
İLK
ÜRETİCİSİ

FIRST
PRODUCER
IN TURKEY

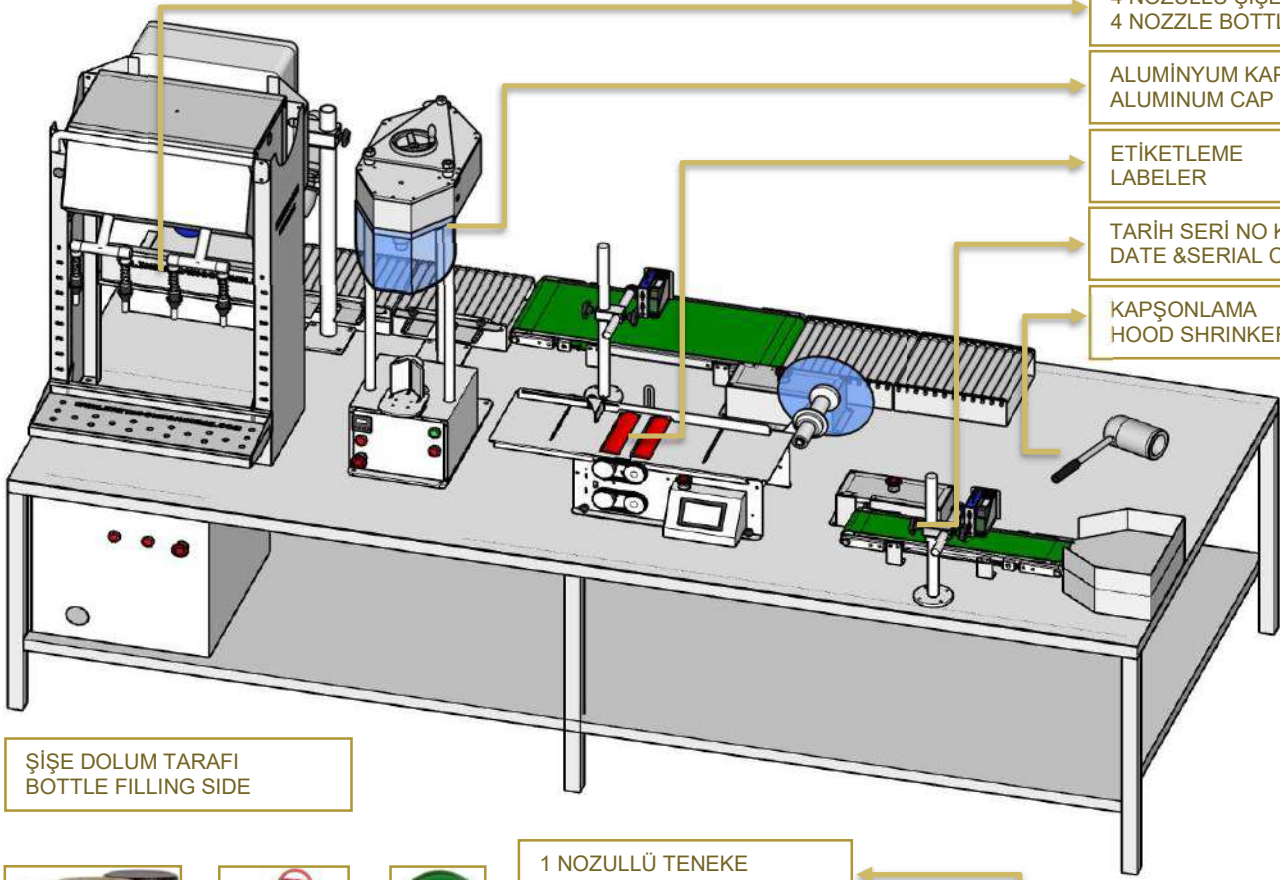

4 NOZULLU ŞİŞE DOLUM
4 NOZZLE BOTTLE FILLER

ALUMİNYUM KAPAK SIVAMA
ALUMINUM CAP PLASTERER

ETİKETLEME
LABELER

TARİH SERİ NO KODLAMA
DATE & SERIAL CODER

KAPŞONLAMA
HOOD SHRINKER

ŞİŞE DOLUM TARAFI
BOTTLE FILLING SIDE



1 NOZULLU TENEKE
DOLUM

PLASTİK KAPAK ÇAKMA
PLASTIC CAP TACKER

TARİH SERİ NO KODLAMA
DATE & SERIAL CODING

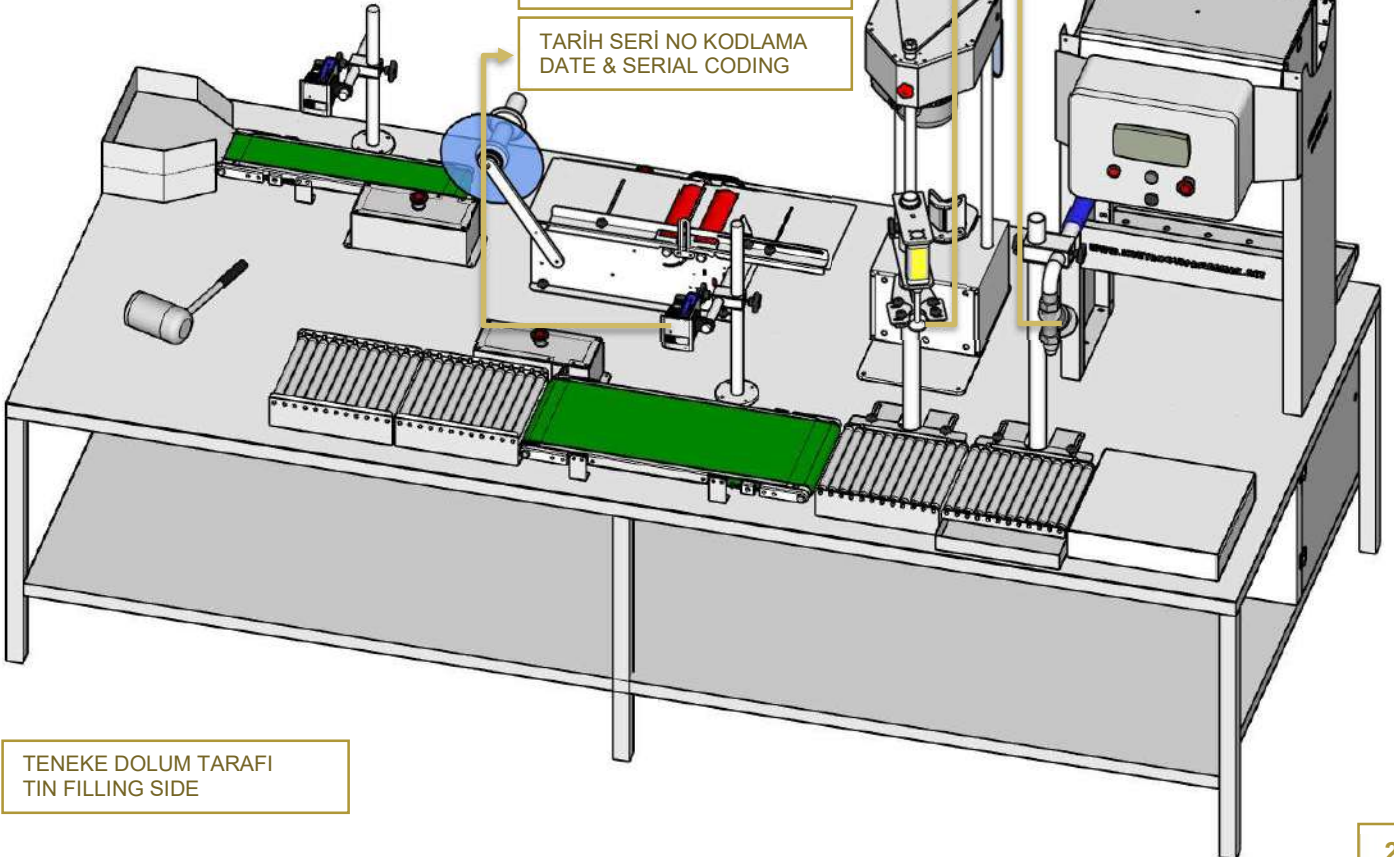

TENEKE DOLUM TARAFI
TIN FILLING SIDE



TÜRKİYE'NİN
İLK
ÜRETİCİSİ

FIRST
PRODUCER
IN TURKEY

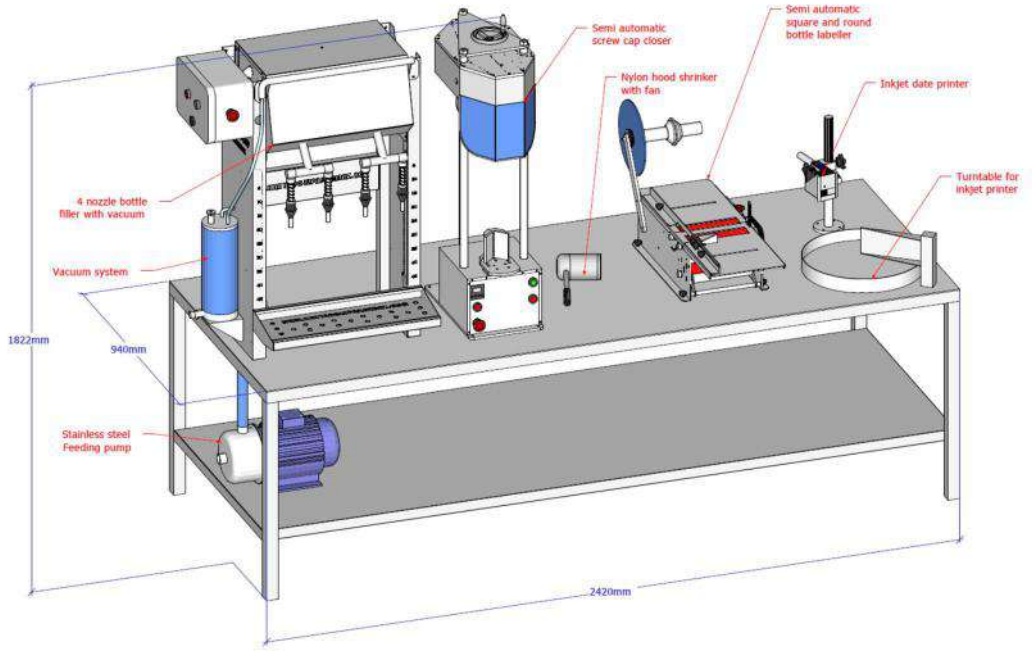

SADECE ŞİŞELEME VEYA TENEKE TARAFI SİPARİŞ VERİLEBİLİR
POSSIBILITY TO ORDER AS ONLY BOTTLE OR TIN FILLING SIDE

MASA ÜSTÜ KAPAK KAPAMA TABLETOP CAPPERS

MTK – MANUEL TENEKE / ŞİŞE KAPAKLAMA
MTK – MANUAL TIN / BOTTLE CAPPER
ÇAKMA KAPAKLAR İÇİNDİR / FOR PRES ON CAPS
P1 – PNEUMATIC TIN / BOTTLE CAPPER
P1 – PNÖMATİK TENEKE / ŞİŞE KAPAKLAMA
ÇAKMA KAPAKLAR İÇİNDİR
FOR PRES ON CAPS



MTK



P1

MANUEL MANTARLAMA MANUAL CORKING

MM1 – PLASTİK YUVALI MANTARLAMA
MM1 – CORKER WITH PLASTIC JAW
MM2 – PİRİNÇ YUVALI MANTARLAMA
MM2 – CORKER WITH BRASS JAW
MM3 – MAGNUM TİPİ ŞİŞELER İÇİN MANTARLAMA
MM3 – CORKER FOR MAGNUM TYPE BOTTLES



MM1



MM2



MM3

YARI OTOMATİK MANTARLAMA SEMI-AUTOMATIC CORKING

PNEUS15 – YARI OTOMATİK MANTAR ÇAKMA MAKİNESİ
PNEUS15 – SEMI-AUTOMATIC CORKING MACHINE
PNEUS37 – YARI OTOMATİK MANTAR ÇAKMA MAKİNESİ
PNEUS37 – SEMI-AUTOMATIC CORKING MACHINE
PNEUS47 – YARI OTOMATİK MANTAR ÇAKMA MAKİNESİ
PNEUS47 – SEMI-AUTOMATIC CORKING MACHINE
PNEUS57 – YARI OTOMATİK MANTAR ÇAKMA MAKİNESİ
PNEUS57 – SEMI-AUTOMATIC CORKING MACHINE

DOLUM ÖNCESİ AZOT ENJEKSİYON SİSTEMİ, MANTAR BUNKERİ GİBİ
OPSİYONLAR MEVCUTTUR
NITROGEN INJECTION SYSTEM, CORK BUNKER IS OPTIONAL



PNEUS 15



PNEUS 47



PNEUS 37



PNEUS 57

ALUMİNYUM / TAÇ KAPAK KAPAMA ALUMINIUM / CROWN CAP CLOSERS

KS1 – ALÜMİNYUM KAPAK SIVAMA
KAPAKLAR KENDİNDEN YİVLİ OLMALIDIR
MKK1 – TAÇ KAPAK SIVAMA

KS1 – ALUMINUM CAP CLOSER
CAPS MUST BE SELF THREADED
MKK1 – CROWN CAP CLOSER



TÜRKİYE'NİN
İLK
ÜRETİCİSİ

FIRST
PRODUCER
IN TURKEY



MKK1



KS1

* SADECE KENDİNDEN YİVLİ KAPAKLARA UYGUNDUR
* SUITABLE FOR PRETHREADED ALUMINUM CAPS

* KENDİNDEN YİVLİ KAPAKLARI FİRMAMIZDAN TEMİN
EDEBİLİRSİNİZ
* PRETHREADED CAPS CAN BE SUPPLIED FROM US

OTOMATİK ALUMİNYUM KAPAK KAPAMA AUTOMATIC ALUMINIUM CAP CLOSER

OKS 1

OTOMATİK KAPAK BESLEME / AUTOMATIC CAP FEEDER
YILDIZ SETLERİ / STAR SETS
PLC DOKUNMATİK EKREN / PLC TOUCH SCREEN
250ML – 2 LT ŞİŞELER / 250 ML – 2 LT BOTTLES



ALUMİNYUM KAPAK KAPAMA ALUMINIUM CAP CLOSERS

PAKS 3 – 4 YARI OTOMATİK KAPAK SIVAMA MAKİNESİ
PAKS 3 – 4 SEMI AUTOMATIC ALUMINIUM CAP CLOSER

3 VEYA 4 DİSKLİ MODEL SEÇİLEBİLİR
3 OR 4 DISCS CAN BE CHOSEN
ZAMAN RÖLELİDİR
WITH TIMER RELAY



TÜRKİYE'NİN
İLK
ÜRETİCİSİ

FIRST
PRODUCER
IN TURKEY



PAKS3



PAKS4

ALUMİNYUM KAPAK KAPAMA ALUMINIUM CAP CLOSERS

RE300 – YARI OTOMATİK KAPAK SIVAMA MAKİNESİ
RE300 – SEMI AUTOMATIC ALUMINIUM CAP CLOSER

RE400 – YARI OTOMATİK KAPAK SIVAMA MAKİNESİ
RE400 – SEMI AUTOMATIC ALUMINIUM CAP CLOSER

RE500 – YARI OTOMATİK KAPAK SIVAMA MAKİNESİ
RE500 – SEMI AUTOMATIC ALUMINIUM CAP CLOSER



RE400



RE300



RE500

ŞİŞE YIKAMA MAKİNELERİ BOTTLE WASHING MACHINES



34210



34220

**NAYLON KAPÜŞONLAMA
NYLON HOOD SHRINKERS**

55400 – FANLI İNOX / WITH FAN İNOX
55500 – FANSIZ / WITHOUT FAN
55300 – MASA ÜSTÜ İNOX / TABLE TOP İNOX



55400

55500



55500

**PLASTİK KAPÜŞONLAMA
PLASTIC HOOD SHRINKER**



**ALUMİNYUM KAPÜŞONLAMA
ALUMINIUM HOOD SHRINKER**



**ALUMİNYUM KAPÜŞONLAMA
ALUMINIUM HOOD SHRINKER**



KONVEYÖLER – CONVEYORS

K20
KAPÜŞONLAMA TÜNELLİ / HOOD SHRINKING TUNNEL
2,5 m KONVEYÖRLÜ / WITH 2,5 m CONVEYOR
DİJİTAL TERMOSTAT / DIGITAL THERMOSTATE
4 KW ISITMA TÜNELLİ / 4 KW HEATER
ISI HOMOJENİZASYON FANLI / WITH HEAT
HOMOGENIZING
INKJET YAZICILAR İLE KULLANILABİLİR /
CAN ALSO BE USED FOR INKJET PRINTERS

K1
KONVEYÖR – CONVEYOR
İSTENEN BOYDA ÜRETİLİR
CAN BE MANUFACTURED AT DESIRED LENGTH

B1
INKJET İÇİN KONVEYÖR
CONVEYOR FOR INKJET PRINTERS



EMNİYET BANDI BÜZME TÜNELLİ SAFETY SEAL SHRINK TUNNEL

EM 10
İSTENEN BOYDA ÜRETİLİR
DİJİTAL TERMOSTAT
4KW ISITMA TÜNELLİ
ISI HOMOJENİZASYON FANLI
INKJET YAZICILAR İLE KULLANILABİLİR

CAN BE MANUFACTURED AT DESIRED LENGTH
DIGITAL THERMOSTAT
4 KW HEATER
WITH HEAT HOMOGENIZING FAN
CAN ALSO BE USED FOR INKJET PRINTERS



MASA ÜSTÜ MANUEL ETİKETLEME TABLETOP MANUAL LABELLERS

E1 – MANUEL YUVARLAK AMBALAJ ETİKETLEME
E1 – MANUEL ROUND CONTAINER LABELLER
E1R – RİBON TARİHLEMELİ E1
E1R – WITH RIBON DATER E1
* SADECE TAM YUVARLAK AMBALAJLAR İÇİN
* SUITABLE FOR ONLY FULL ROUND PACKAGES



TÜRKİYE'NİN
İLK ÜRETİCİSİ

FIRST
PRODUCER
IN TURKEY



E1



E1R

MASA ÜSTÜ YARI OTOMATİK ETİKETLEME TABLETOP SEMI-AUTOMATIC LABELLERS

OE2 – YARI OTOMATİK YUVARLAK AMBALAJ ETİKETLEME
OE2 – SEMI AUTOMATIC ROUND CONTAINER LABELLER

*SADECE TAM YUVARLAK AMBALAJLAR İÇİN ÖN/ARKA ETİKETLEME
*ONLY FOR LABELING DOUBLE SIDE OF FULL ROUND PACKAGES

OE2 PLUS – YARI OTOMATİK YUVARLAK/KARE AMBALAJ ETİKETLEME
OE2 PLUS – SEMI AUTOMATIC ROUND/SQUARE CONTAINER LABELLER



TÜRKİYE'NİN
İLK ÜRETİCİSİ

FIRST
PRODUCER
IN TURKEY

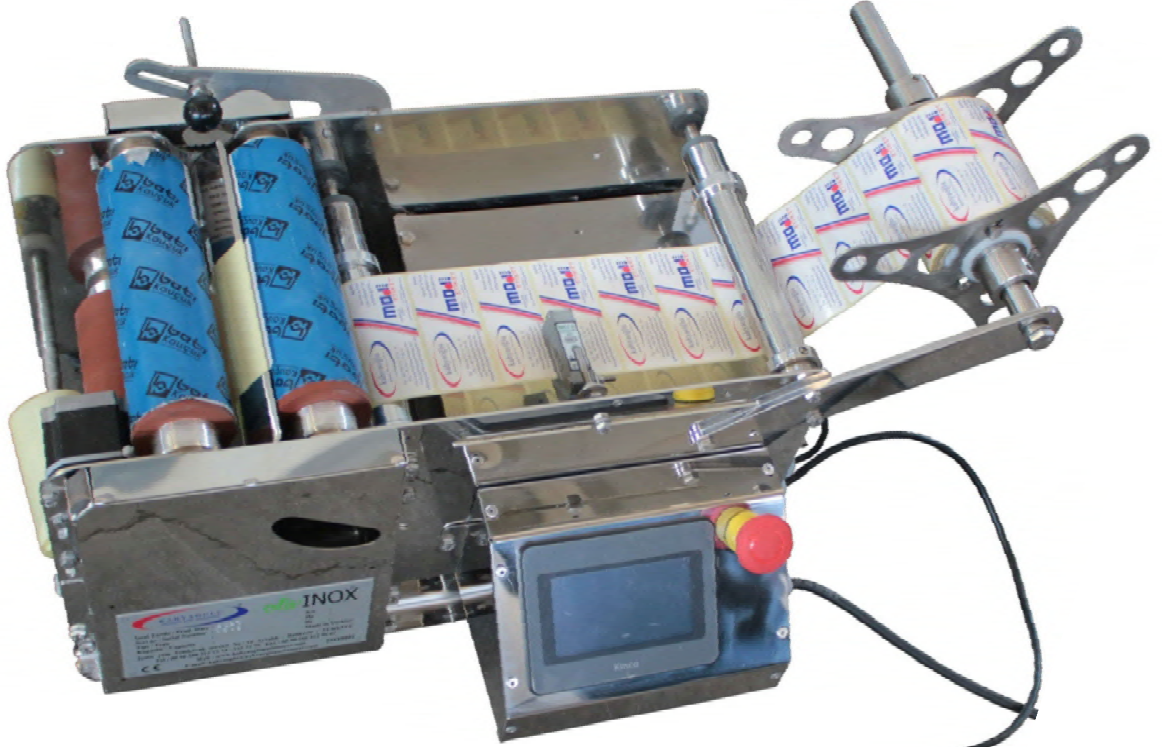

OE2



OE2PLUS

EKONOMİK OTOMATİK ETİKETLEME MAKİNELERİ ECONOMIC AUTOMATIC LABELLERS

OEK 1 P – KARE AMBALAJ İÇİN ÖN ETİKETLEME MAKİNESİ
OEK 1 P – FRONT LABELLER FOR SQUARE CONTAINERS
OEK 2 P – KARE AMBALAJ İÇİN ÖN VE ARKA ETİKETLEME MAKİNESİ
OEK 2 P – FRONT AND BACK LABELLER FOR SQUARE CONTAINERS
OEK 1 R – YUVARLAK AMBALAJ İÇİN ÖN ETİKETLEME MAKİNESİ
OEK 1 R – FRONT LABELLER FOR ROUND CONTAINERS
OEK 2 R – YUVARLAK AMBALAJ İÇİN ÖN VE ARKA ETİKETLEME MAKİNESİ
OEK 2 R – FRONT AND BACK LABELLER FOR ROUND CONTAINERS
OEK 1 U – KARE AMBALAJ İÇİN ÜST ETİKETLEME MAKİNESİ
OEK 1 U – UPPER LABELLER FOR SQUARE CONTAINERS
* KAPUŞON TÜNELİ EKLENEBİLİR – HOOD SHRINHER CAN BE ADDED

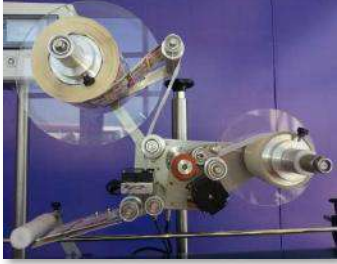

OTOMATİK ETİKETLEME MAKİNELERİ AUTOMATIC LABELLERS

PRO 1 P – KARE AMBALAJ İÇİN ÖN ETİKETLEME MAKİNESİ
PRO 1 P – FRONT LABELLER FOR SQUARE CONTAINERS
PRO 2 P – KARE AMBALAJ İÇİN ÖN VE ARKA ETİKETLEME MAKİNESİ
PRO 2 P – FRONT AND BACK LABELLER FOR SQUARE CONTAINERS
PRO 1 R – YUVARLAK AMBALAJ İÇİN ÖN ETİKETLEME MAKİNESİ
PRO 1 R – FRONT LABELLER FOR ROUND CONTAINERS
PRO 2 R – YUVARLAK AMBALAJ İÇİN ÖN VE ARKA ETİKETLEME MAKİNESİ
PRO 2 R – FRONT AND BACK LABELLER FOR ROUND CONTAINERS
PRO 1 U – KARE AMBALAJ İÇİN ÜST ETİKETLEME MAKİNESİ
PRO 1 U – UPPER LABELLER FOR SQUARE CONTAINERS
PRO 1 P 1R – KARE VE YUVARLAK AMBALAJ İÇİN TEK ETİKETLEME MAKİNESİ
PRO 1 P 1R – 1 SIDE LABELLER FOR ROUND AND SQUARE CONTAINER
PRO 2 P 2R – KARE VE YUVARLAK AMBALAJ İÇİN 2 YÖN ETİKETLEME MAKİNESİ
PRO 2 P 2R – 2 SIDE LABELLER FOR ROUND AND SQUARE CONTAINER
* KAPUŞON TÜNELİ EKLENEBİLİR – HOOD SHRINHER CAN BE ADDED



MÜREKKEP PÜSKÜRTMELİ YAZICILAR – INKJET PRINTERS

TÜM ÜRÜNLER İÇİN



PD LITE

4 SATIR – 4 LINE
SOLVENTSİZ – WITHOUT
SOLVENT
KONVEYÖRLER İÇİNDİR – FOR
CONVEYERS
OPTİK SENSÖR – OPTICAL
SENSOR
NUMERİK KLAVYE – NUMERIC
KEYBOARD

PD 18

4 SATIR – 4 LINE
SOLVENTSİZ – WITHOUT
SOLVENT KONVEYÖRLER İÇİNDİR
– FOR CONVEYERS
OPTİK SENSÖR – OPTICAL
SENSOR
DOKUNMATİK EKREN – TOUCH
SCREEN
BARKOD – SQUARE CODE



TJET

6 LINE – 6 SATIR
SOLVENTLİ – WITH SOLVENT
KONVEYÖRLER İÇİNDİR
FOR CONVEYERS
OPTİK SENSÖR – OPTİK SENSÖR
TOUCH SCREEN – TOUCH SCREEN
600 DPI ÇÖZÜNÜRLÜK – RESOLUTION
BARKOD VE KARE KOD ÖZELLİĞİ
BARCODE – SQUARE CODE



KHX

4 SATIR – 4 LINE
SOLVENTLİ/SU BAZLI
SOLVENT/WATER BASED
KONVEYÖRLER İÇİNDİR
FOR CONVEYERS
OPTİK SENSÖR – OPTICAL SENSOR
PC BAĞLANTISI – PC CONNECTION
600 DPI ÇÖZÜNÜRLÜK – RESOLUTION
BARKOD VE KARE KOD ÖZELLİĞİ
BARCODE – SQUARE CODE

KALEM TİP YAZICILAR PEN PRINTERS

KALEMJET – 1 SATIR / 1 LINE
* KALEMJET İÇİN SOLVENTLİ
SEÇENEK YOKTUR
* THERE IS NO SOLVENTED INK
OPTION FOR KALEMJET

SADECE EMİCİ YÜZEYLER İÇİN
ONLY FOR ABSORBENT SURFACES



KALEMJET

KAŞE TİP YAZICILAR STAMP PRINTERS

KAŞEJET 790 – 2 SATIR / 2 LINE
KAŞEJET 970 – 6 SATIR / 6 LINE
TJETHM6 – 8 SATIR / 8 LINE



KAŞEJET790

TÜM AMBALAJLAR İÇİN
FOR ALL PACKING



KAŞEJET970

RENKLİ TARİH / SERİ NO KODLAMA COLOR PRINTER

PEKOKO
1 SATIR / 1 LINE
BLUETOOTH
ANDROID / IOS



TABANCA TİP YAZICI HAND PRINTER

TJETHM6 – 8 SATIR / 8 LINE



LAZER YAZICI LASER PRINTER

L3
1 SATIR / 1 LINE
MÜREKKEPSİZ / WITHOUT INK



INKJET YAZICI / INKJET PRINTER

MX1
2 – 12,7 MM SATIR ARALIĞI / LINE GAP



2 KAFALI INKJET YAZICI INKJET PRINTER WITH TWO HEADS

MX2
2 – 25,4 MM SATIR ARALIĞI / LINE GAP



ŞRİNK PAKETLEME TÜNELİ SHRINK PACKING TUNNEL

SHRINK 6 KW 3F
ISI HOMOJENİZASYON FANI – HEAT HOMOGENIZING FAN
SOĞUTMA FANI – COOLING FAN
PNÖMATİK TERMAL NAYLON KESME CENESİ – PNEUMATIC THERMAL NYLON CUTTING



ÇALIŞMA TEZGAHI MODELLERİ WORK BENCHES

525 x 525 MM TEK KATLI – ÇİFT KATLI / 1 OR 2 LAYERS
525 x 1150 MM TEK KATLI – ÇİFT KATLI / 1 OR 2 LAYERS
650 x 650 MM TEK KATLI – ÇİFT KATLI / 1 OR 2 LAYERS
650 x 1400 MM TEK KATLI – ÇİFT KATLI / 1 OR 2 LAYERS
650 x 1900 MM TEK KATLI – ÇİFT KATLI / 1 OR 2 LAYERS
900 x 900 MM TEK KATLI – ÇİFT KATLI / 1 OR 2 LAYERS
900 x 1400 MM TEK KATLI – ÇİFT KATLI / 1 OR 2 LAYERS
900 x 1900 MM TEK KATLI – ÇİFT KATLI / 1 OR 2 LAYERS
900 x 2900 MM TEK KATLI – ÇİFT KATLI / 1 OR 2 LAYERS



STOKLAMA – DİNLENDİRME – FERMANTASYON – PROSES TANKLARIMIZ



TÜRKİYE'NİN
İLK ÜRETİCİSİ

İMALAT YAPTIĞIMIZ SEKTÖRLER

- ZEYTİNYAĞI
- TÜM BİTKİSEL YAĞLAR
- TÜM ALKOLLÜ İÇECEKLER
ŞARAP RAKI BİRA VODKA
CİDER V.B.
- SİRKE
- PEKMEZ
- BAL
- MEYVE SUYU
- SÜT
- SALÇA KETÇAP MAYONEZ
- SU
- SABUN
- KOZMETİK
- KİMYA
- ÇİKOLATA
- NAR EKŞİSİ

TEKNİK RESİMLERDE
VERİLMİŞ OLAN
MODELLER ÖRNEK
OLARAK VERİLMİŞTİR

25 LT DEN 500 TON
KAPASİTEYE KADAR
TALEPLERİNİZE GÖRE
DİZAYN EDEREK
İHTİYACINIZ OLAN
TANKLARIN İMALATINI
YAPMAKTAYIZ.

İMAL ETTİĞİMİZ TANK TİPLERİ

- GÜĞÜMLER
- DÜZ DİPLİ (AYAKSIZ) LANCALAR
- EĞİK DİPLİ, AYAKLI LANCALAR
- KONİK DİPLİ, AYAKLI LANCALAR
- MAMUL TAŞIMA ARABALARI
- YÜZER KAPAKLI LANCALAR
- YÜZER KAPAKLI EĞİK DİPLİ LANCALAR
- DÜZ DİPLİ, AYAKSIZ TANKLAR
- KONİK DİPLİ, AYAKLI TANKLAR
- EĞİK DİPLİ, AYAKLI TANKLAR
- ARMUT DİPLİ, AYAKLI TANKLAR
- ARMUT DİPLİ VE GÖVDELİ TANKLAR
- TERS KONİK DİPLİ, AYAKLI TANKLAR
- OTOMATİK BOŞALTIMA İÇİN KAZIYICILI DİPLİ,
AYAKLI/AYAKSIZ TANKLAR
- YUVARLAK DİPLİ, PRİZMATİK, AYAKLI TANKLAR
- PRİZMATİK, AYAKLI/AYAKSIZ TANKLAR
- OVAL YATIK AYAKLI/AYAKSIZ TANKLAR
- YUVARLAK YATIK AYAKLI TANKLAR
- REAKTÖRLER
- BAL TANKLARI
- SABUN PİŞİRME TANKLARI
- VAKUMLU PİŞİRME KAZANLARI
- ARAÇ ÜSTÜ TANKLAR
- SÜT NAKİL TANKLARI
- SÜT SOĞUTMA TANKLARI (YATAY DİKEY)
- CIP TANKLARI
- SÜT PİŞİRME TANKLARI
- PEYNİR TEKNESİ
- ÖZEL TİP ZEYTİNYAĞI DİNLENDİRME TANKLARI (DERİN
KONİKLİ)
- BÜYÜK HACİMLİ TANKLAR (YERİNDE İMAL EDİLİR)

İMALATLARIMIZDA SEÇEBİLECEĞİNİZ ÖZELLİKLER

- YÜZER KAPAK, GEÇME KAPAK, CONTALI SIZDIRMAZ KAPAK
- AZOT SİSTEMİ UYUMLULUĞU
- YÜZE YAKIN DEĞİŞİK MODELDE, ÖZELLİKTE VE ÇAPTA MANHOLE VE CİBRE
KAPAKLARI
- YÜZLERCE DEĞİŞİK VANA, HAVA KİLİDİ V.B. AKSESUAR
- KARIŞTIRICI (DİKEY, YANDAN, DİPTEN) (ÇAPA TİPİ, KAZIYICILI, PERVANE TİPİ
V.B. TİPLER)
- İZOLASYON (İSITMA VEYA SOĞUTMA)
- SOĞUTMA / İSITMA CİDARI (ROLLBOND, DİMPLE, HAVŞALI DİMPLE, DİKİŞ
KAYNAKLI)
- SERPANTİN (DIŞTAN / İÇTEN) YARIM BORU /TAM BORU, U TİPİ)
- LOADCELL VE İNDİKATÖRLÜ TARTIM ÖZELLİĞİ
- MERDİVEN, GEMİCİ MERDİVENİ, YÜRÜME YOLLARI
- BORU TESİSATI
- CIP YE UYUMLULUK
- TİMERLİ (ZAMAN AYARLI) SİRKÜLASYON ÖZELLİĞİ)
- SİRKÜLASYON POMPASI
- ÇİN ŞAPKASI, ROTATİF DUŞLAMA, CIP YIKAMA TOPU
- SOĞUTMA OTOMASYONU VE CEKET İÇİN SELENOİD VALF
- AYARLI AYAKLAR
- AYAK BOYU
- KONİK DERİNLİĞİ
- DALDIRMA TİP EŞANJÖRLER
- HİDROLİK CİBRE KAPAĞI
- OTOMATİK CİBRE BOŞALTIMA SİSTEMİ
- SICAKLIK ALARMI
- TANK VANA VE POMPA OTOMASYONU.
- DOKUNMATİK EKRANLI PROGRAMLANABİLİR PLC KONTROL PANELİ
- MALZEME CİNSİ AISI 304 – AISI 304 L – AISI 316 – AISI 316 L
- MALZEME DESENLERİ 2B MAT – 4N TAŞLI – MF4 BALIKSIRTI PUL DESENLİ – AB /
BA PARLAK
(PARLAK SAÇ HER KALINLIKTA SAC BULUNAMADIĞINDAN HER MODEL İÇİN
GEÇERLİ DEĞİLDİR.)
- VE BURADA BELİRTİLMEMİŞ DAHA BİRÇOK ÖZELLİK SEÇİLEBİLİR....

STOCKING – SETTLING – FERMANTATION – PROCESS TANKS



FIRST
PRODUCER IN
TURKEY

SECTORS WE MANUFACTURE

- OLIVE OIL
- ALL VEGETAL OIL
- ALL ALCOHOLIC DRINKS, WINE, BEER, VODKA, CIDER...
- VINEGAR
- MOLASSES
- HONEY
- JUICE
- MILK
- TOMATO PASTE, KETCHUP, MAYONNAISE
- WATER
- SOAP
- COSMETICS
- CHEMISTRY
- CHICOLATE
- POMEGRANATE SYRUP

MODELS GIVEN IN
TECHNICAL DRAWINGS
ARE GIVEN AS SAMPLES

WE DESIGN AND
MANUFACTURE TANKS
WITH CAPACITY OF
25 LT. TO 500 TONS
FOR VARIOUS
REQUESTS

TANK TYPES WE MANUFACTURE

- DRUMS
- SIMPLE TANKS WITH FLAT BOTTOM AND WITHOUT LEGS
- SIMPLE TANKS WITH LEGS AND INCLINED BOTTOM
- SIMPLE TANKS WITH LEGS AND CONICAL BOTTOM
- PRODUCT CARRIAGE TANKS
- SIMPLE TANKS WITH FLOATING LIDS
- SIMPLE TANKS WITH FLOATING LID AND INCLINED BOTTOM
- TANKS WITH FLAT BOTTOM AND WITHOUT LEGS
- TANKS WITH LEGS AND CONICAL BOTTOM
- TANKS WITH LEGS AND INCLINED BOTTOM
- TANKS WITH LEGS AND TRAPEZOID BOTTOM
- TANKS WITH CAMBER AND TRAPEZOID BOTTOM
- TANKS WITH LEGS AND REVERSE KONICAL BOTTOM
- TANKS WITH/WITHOUT LEGS AND WITH BOTTOM SCRAPER FOR AUTOMATIC DISCHARGE
- PRISMATIC TANKS WITH LEGS AND CIRCULAR BOTTOM
- PRISMATIC TANKS WITH/WITHOUT LEGS
- OVAL HORIZONTAL TANKS WITH/WITHOUT LEGS
- CIRCULAR HORIZONTAL TANKS WITH LEGS
- REACTORS
- HONEY TANKS
- SOAP COOKING TANKS
- COOKING BOILERS WITH VACUUM
- ON VEHICLE TANKS
- MILK TRANSFER TANKS
- MILK COOLING TANKS (VERTICAL / HORIZONTAL)
- CIP TANKS
- MILK COOKING TANKS
- CHEESE PREPARATION TANKS
- SPECIAL TYPE OLIVE OIL SETTLING TANKS (DEEP CONICAL BOTTOM)
- HUGE VOLUME TANKS (MANUFACTURED ON SITE)

PREFERABLE FEATURES FOR MANUFACTURE

- LOADING LIDS, SNAP COVERS, SEALED LEAK PROOF COVERS
- NITROGEN INJECTION SYSTEM COMPATIBILITY
- NEARLY HUNDERED OF MANHOLE AND POMACE COVERS IN VARIOUS MODELS, FEATURES AND SIZES
- HUNDREDS OF TYPES OF VALVES, AIRLOCKS AND ACCESSORIES
- MIXERS (VERTICAL, HORIZONTAL, BOTTOM) (GRUBBER TYPE, SCRAPER, PROPELLER TYPE...)
- ISOLATION (HEATING AND COOLING)
- COOLING AND HEATING WALSS (ROLLBOND, DIMPLE, COUNTERSINKED DIMPLE, SEAM WELDED)
- SERPENTINE (INNER / OUTER) HALF PIPE / FULL PIPE, U TYPE)
- WEIGHING FEATURE WITH INDICATOR OR LOADCELL
- LADDERS, WALK PATHS
- PIPING
- CIP COMPATIBILITY
- CIRCULATION FEATURE WITH TIMER
- CIRCULATION PUMP
- CHINA HAT CAP, ROTATIVE SHOWERING, CIP WASHING BALL
- SELENOID VALVE FOR CHILLER COAT AND AUTOMATION
- ADJUSTABLE FEET
- VARIOUS LEG HEIGHT
- VARIOUS CONICAL DEPTH
- SUBMERSIBLE TYPE HEAT EXCHANGERS
- HYDRAULIC MUST DOOR
- AUTOMATIC MUST DICHAERGE SYSTEM
- OVERHEATING ALARM
- VALVE AND PUMP AUTOMATION FOR TANKS
- PROGRAMMABLE PLC CONTROL PANEL WITH TOUCH SCREEN
- STAINLESS STEEL TYPES: AISI 304 – AISI 304 L – AISI 316 – AISI 316 L
- MATERIAL PATTERNS: 2B MATT – 4N BRUSHED – MF4 ROUND SHAPES – AB / BA BRIGHT
(BRIGHT SHEET IS NOT AVAILBLABE IN EVERY THICKNESS, SO SOME MODELS ARE AVAILABLE)
- AND SO MANY PREFERABLE FEATURES THAT ARE NOT METIONED HERE....

- DÜZ DİPLİ GÜĞÜMLER
- DRUMS



G100 - 100



G50 - 50 LİTRE



G30 - 30 LİTRE



G20 - 20 LİTRE



G10 - 10 LİTRE



G5 - 5 LİTRE



G2 - 2 LİTRE

* 5 VE 2 LİTRELİK GÜĞÜMLERİN
PAKETİNE MUSLUK DAHİLDİR
* SPIGOT IS INCLUDED FOR 2 AND 5
LITER DRUMS



MUSLUK -



STAND



ZEYTİNYAĞI
ŞARAP
BİRA
MEYVE SUYU
BAL
SÜT
SİRKE

OLIVE OIL
WINE
BEER
FRUIT JUICE
HONEY
MILK
VINEGAR

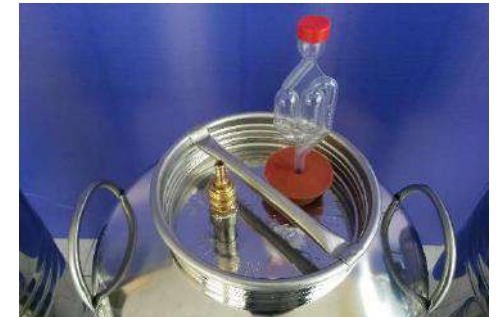

- DÜZ DİPLİ (AYAKSIZ) LANCA TİPİ DEPOLAMA TANKLARI
- SIMPLE STORAGE TANKS WITH FLAT BOTTOM (WITHOUT LEGS)



ZEYTİNYAĞI
ŞARAP
BİRA
MEYVE SUYU
BAL
SÜT
SİRKE

OLIVE OIL
WINE
BEER
FRUIT JUICE
HONEY
MILK
VINEGAR

SIMPLE FLAT BOTTOM TANKS - DÜZ DİPLİ LANÇALAR TB 2000 - TB 1000 - TB 500 - TB 300 - TB 200

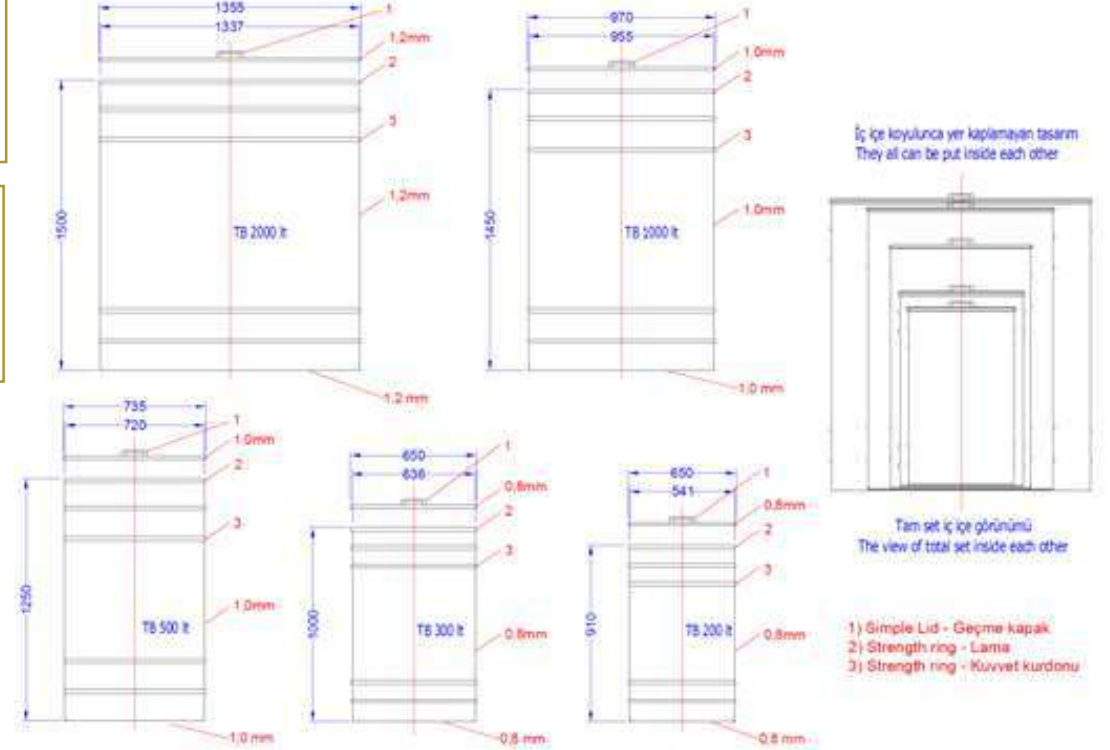

- AYAKLI LANCA TİPİ DEPOLAMA TANKLARI
- SIMPLE STORAGE TANKS WITH FEET



ZEYTİNYAĞI
ŞARAP
BİRA
MEYVE SUYU
BAL
SÜT
SİRKE

OLIVE OIL
WINE
BEER
FRUIT JUICE
HONEY
MILK
VINEGAR

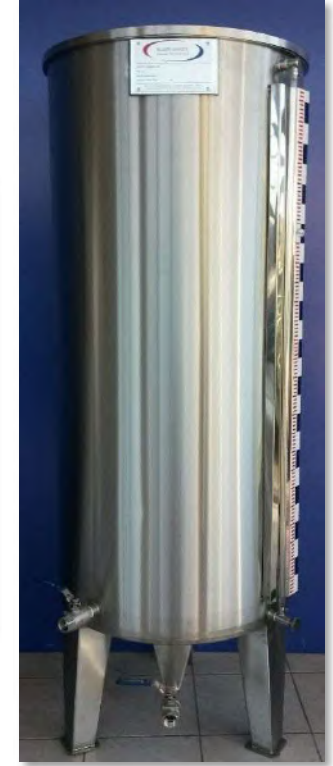

SIMPLE TANKS / LANÇALAR : TD 2200 - TD 1700 - TD 1100 - TD 600 - TD 550 - TD 330 - TD 280 - TD 230

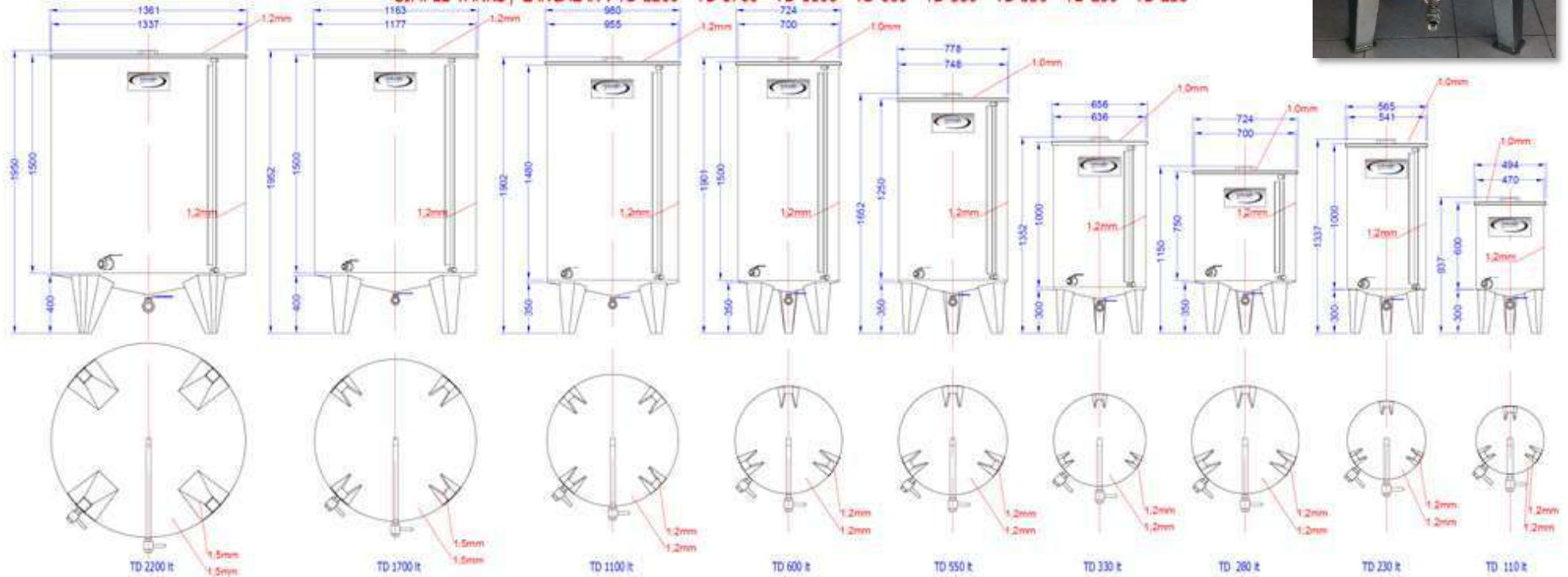

- MAMUL TAŞIMA TANKLARI
- PRODUCT CARRIAGE TANKS



ZEYTİNYAĞI
ŞARAP
BİRA
MEYVE SUYU
BAL
SÜT
SİRKE

OLIVE OIL
WINE
BEER
FRUIT JUICE
HONEY
MILK
VINEGAR



T200



T2000

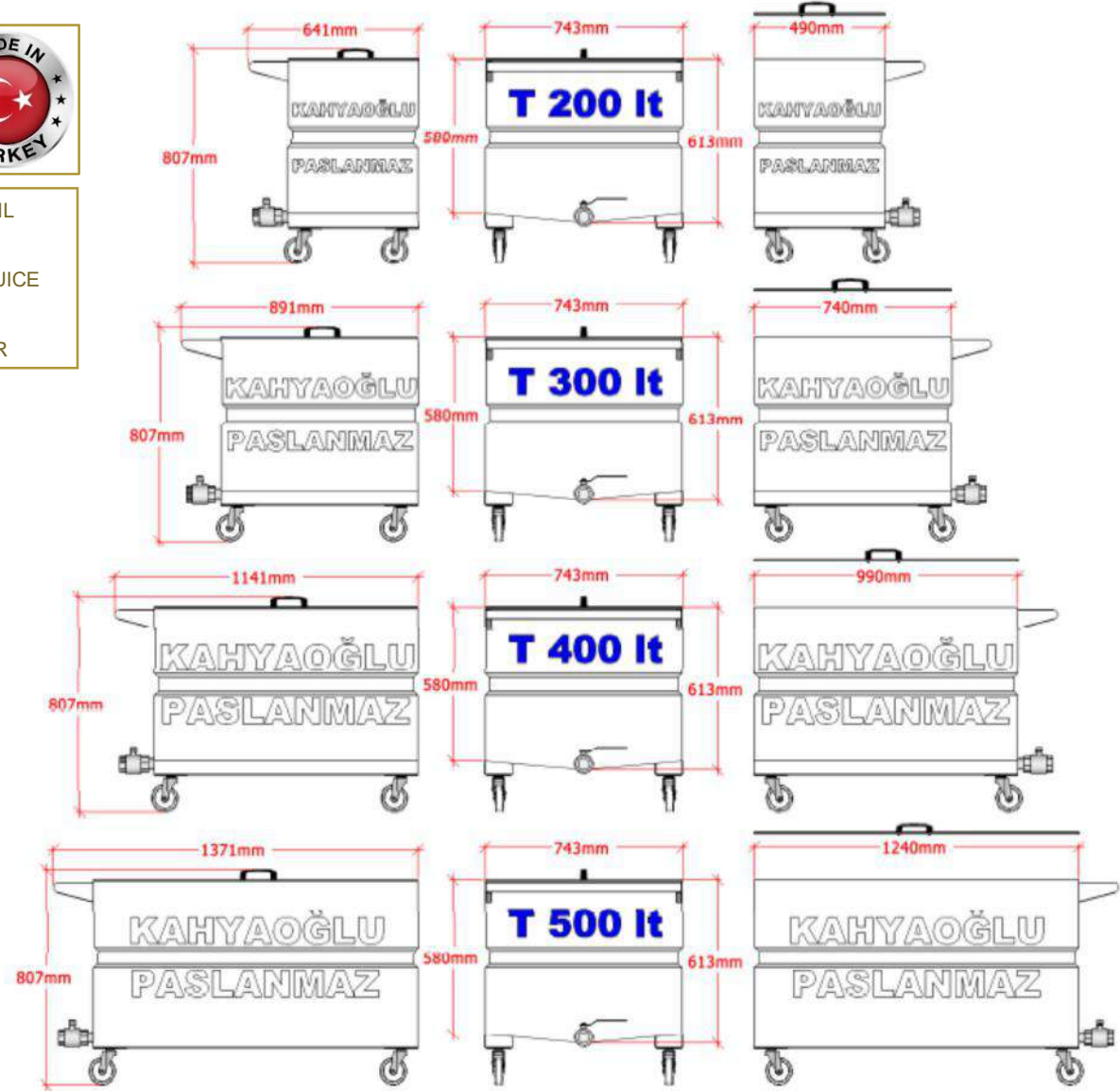

- EĞİK DİPLİ YÜZER KAPAKLI FERMANTASYON VE DEPOLAMA TANKLARI
- FERMENTATION AND STORAGE TANKS WITH INCLINED BOTTOM AND FLOATING LIDS



ZEYTİNYAĞI
ŞARAP
BİRA
MEYVE SUYU
BAL
SÜT
SİRKE

OLIVE OIL
WINE
BEER
FRUIT JUICE
HONEY
MILK
VINEGAR



- YÜZER KAPAKLI LANÇALAR
- SIMPLE TANKS WITH FLOATING LID



ZEYTİNYAĞI
ŞARAP
BİRA
MEYVE SUYU
BAL
SÜT
SİRKE

OLIVE OIL
WINE
BEER
FRUIT JUICE
HONEY
MILK
VINEGAR

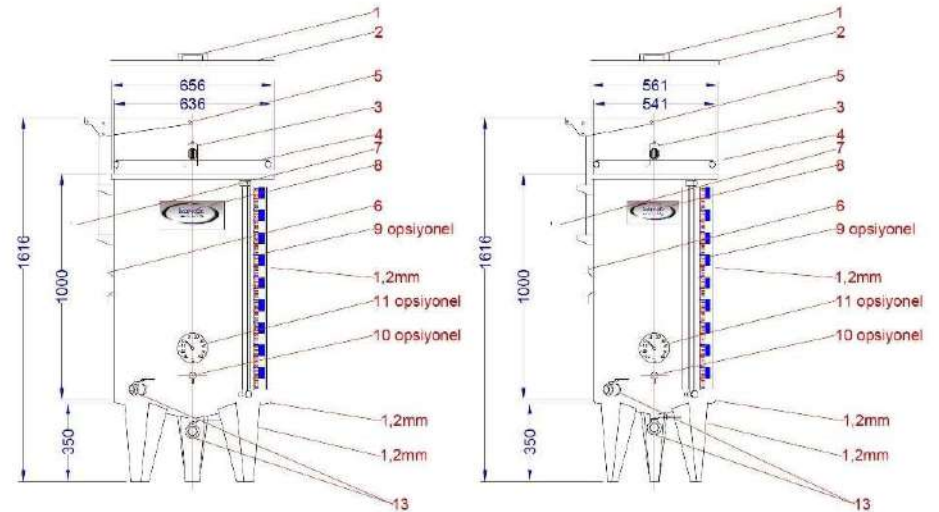
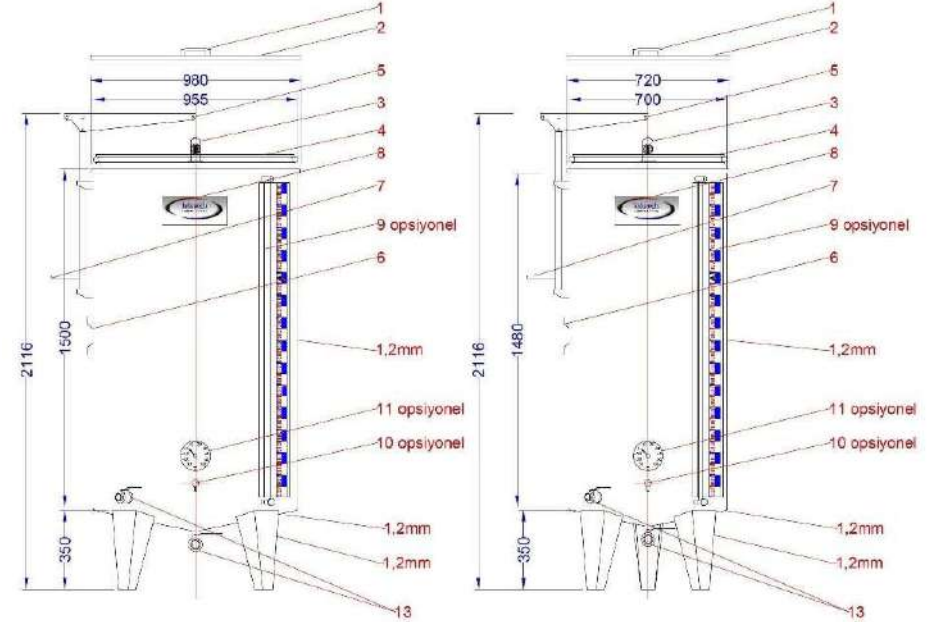

- DÜZ DİPLİ AYAKSIZ STOK TANKLARI
- VERTICAL STOCK TANKS WITH FLAT BOTTOM
- GENİŞ ÇAPLI TANKLAR – LARGE DIAMETER TANKS
- DERİN KONİKLİ TANKLAR – DEEP CONICAL TANKS
- DÜZ DİPLİ TANKLAR – FLAT BOTTOM TANKS
- AYNA PARLAK TANKLAR – POLISHED TANKS
- MAT TANKLAR – MATT TANKS
- BALIK SIRTİ MF4 DESENLİ TANKLAR – MARBLE PATTERN TANKS
- TAŞLI NAYLONLU 4N DESENLİ TANKLAR – 4N PATTERN TANKS



ZEYTİNYAĞI
ŞARAP
BİRA
MEYVE SUYU
BAL
SÜT
SİRKE

OLIVE OIL
WINE
BEER
FRUIT JUICE
HONEY
MILK
VINEGAR



- KONİK DİPLİ AYAKLI STOK TANKLARI
- STOCK TANKS WITH LEGS AND CONICAL BOTTOM



ZEYTİNYAĞI
ŞARAP
BİRA
MEYVE SUYU
BAL
SÜT
SİRKE

OLIVE OIL
WINE
BEER
FRUIT JUICE
HONEY
MILK
VINEGAR











- EĞİK DİPLİ AYAKLI FERMANTASYON TANKLARI
- FERMENTATION TANKS WITH LEGS AND INCLINED BOTTOM



ZEYTİNYAĞI
ŞARAP
BİRA
MEYVE SUYU
BAL
SÜT
SİRKE

OLIVE OIL
WINE
BEER
FRUIT JUICE
HONEY
MILK
VINEGAR



TARTARİZASYON
TANKI –
TARTARIZATION
TANK





- PROSES TANKLARI
- PROCESS TANKS

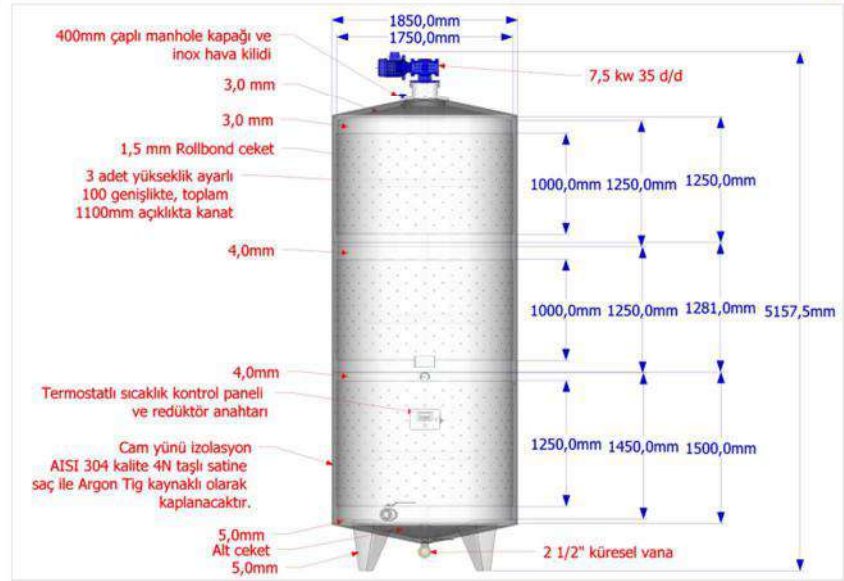
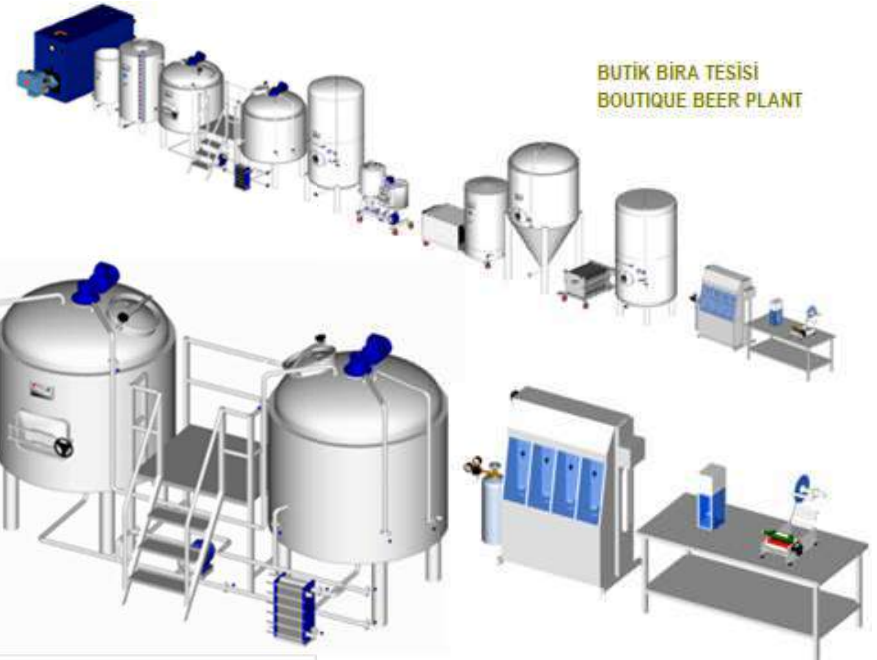
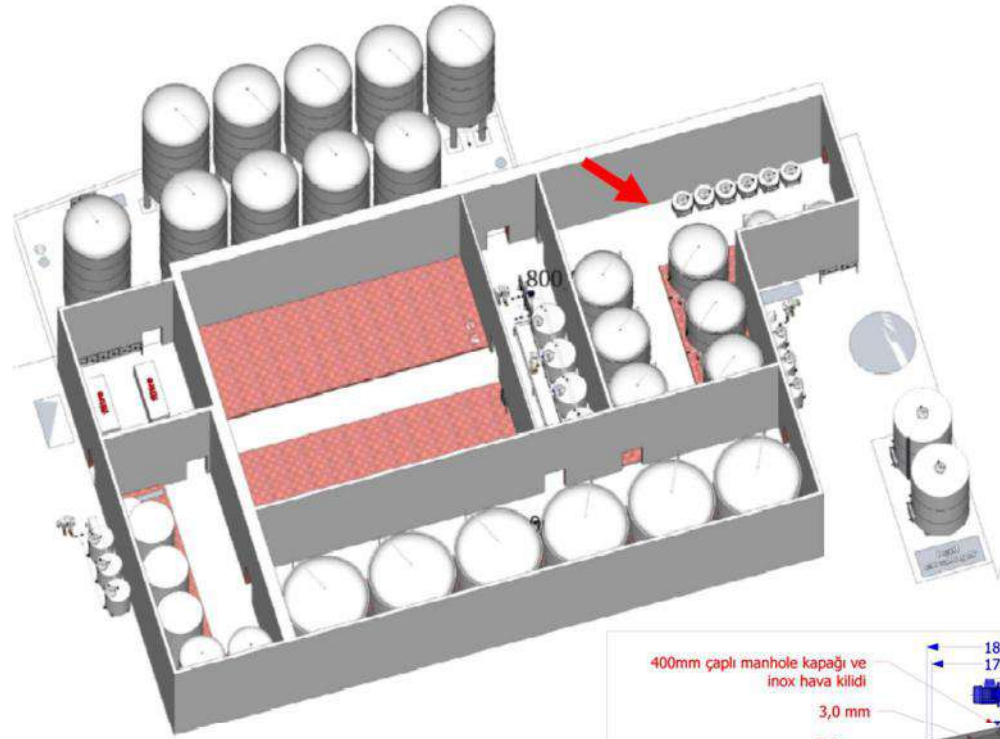





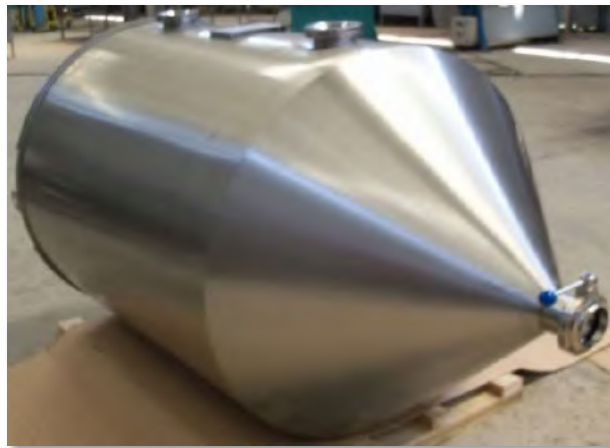

- YATIK TİP STOK TANKLARI
- HORIZONTAL STOCK TANKS



- TANK AKSESUARLARI
- TANK ACCESSORIES



* ÇEŞİTLİ ÇAPLARDA YÜZER KAPAKLAR VE AKSESUARLARI
* FLOATING LIDS IN VARIOUS DIAMETER AND ACCESSORIES

MANHOL – CİBRE KAPAKLARI / MANHOLE POMACE LIDS



KH400



KHOVAL

* ÜST (Ø400 MM) VE YAN KAPAK (450 X 350 MM) İMALATIMIZ MEVCUTTUR
* WE MANUFACTURE OUR OWN TOP AND SIDE COVERS



LOADCELL'LI TANK DOKUNMATİK KONTROL PANELİ
TOUCH SCREEN CONTROL PANEL FOR TANKS WITH LOADCELL



- TANK AKSESUARLARI
- TANK ACCESSORIES



KAMLOK – A CAMLOCK – A	KAMLOK – B CAMLOCK – A	KAMLOK – C CAMLOCK – C
1/2"	1/2"	1/2"
3/4"	3/4"	3/4"
1"	1"	1"
1 1/4"	1 1/4"	1 1/4"
1 1/2"	1 1/2"	1 1/2"
2"	2"	2"
2 1/2"	2 1/2"	2 1/2"

* KAMLOKLAR PASLANMAZ ÇELİK VEYA ALÜMİNYUM OLARAK TEMİN EDİLEBİLİR
* CAMLOCKS CAN BE SUPPLIED EITHER STAINLESS STEEL OR ALUMINIUM



PASLANMAZ ÇELİK KELEBEK VANA STAINLESS STEEL BUTTERFLY VALVE
DN25
DN32
DN40
DN50



PASLANMAZ ÇELİK KÜRESEL VANA STAINLESS STEEL BALL VALVE
DN8 – 1/4"
DN10 – 3/8"
DN15 – 1/2"
DN20 – 3/4"
DN25 – 1"
DN32 – 1 1/4"
DN40 – 1 1/2"
DN50 – 2"
DN65 – 2 1/2"



AY ANAHTARLI RAKOR
UNION



NİPEL
NIPPLE



MANŞON
SLEEVE



TE
TEE



KLEMP TAKIMI
CLAP GEAR



GAROLA KLEMP
GAROLLA CLAMP

- AZOT / ARGON ENJEKSİYON SİSTEMLERİ
- NITROGEN AND ARGON INJECTION SYSTEMS

- AISI 304 KALİTE PASLANMAZ ÇELİKTEN İMALDİR
- TEK TÜP İÇİN DİZAYN EDİLMİŞTİR
- STOK TANKLARINDA 1 HAFTADA UZUN SÜRE SAKLANACAK MAMULLERİN OKSİJEN İLE TEMAS EDEREK BOZULMASINI ÖNLEMENİN AMACIYLA KULLANILIR
- ÇİFT REGÜLATÖRLÜDÜR
- MOBİLDİR, STOK TANKININ YANINA GÖTÜRÜLEREK AZOT HATTINA BAĞLANIR
- TÜP DAHİL DEĞİLDİR
- N2M VE ARM MODELİ KÜÇÜK TÜP İÇİNDİR
- MANUFACTURED FROM AISI304 QUALITY STAINLESS STEEL
- FOR SINGLE GAS CYLINDER
- USED IN STOCK TANKS FOR THE PRODUCTS TO BE STORED FOR MORE THAN 1 WEEK AS TO PREVENT THE LIQUID CONTACT WITH OXYGEN
- DOUBLE REGULATOR
- MOBILE, SIMPLY CONNECTED TO THE NITROGEN INSTALLATION
- GAS CYLINDER NOT INCLUDED
- N2M IS FOR SMALL GAS CYLINDERS



N2S



ARM



N2T



PURJÖR

SIVI AKTARMA POMPALARI LIQUID TRANSFER PUMPS

ÇAK ÇAK POMPALAR EXCENTRIC PUMPS

- 3-4 TON/SAAT YAĞ POMPASI. 1" VEYA 1 1/4" GİRİŞ-ÇIKIŞ, 1500RPM 1,1KW
- 9-10 TON/SAAT YAĞ POMPASI, 1 1/2" GİRİŞ-ÇIKIŞ, 1500RPM 1,5KKW
- 12-14 TON/SAAT YAĞ POMPASI, 2" GİRİŞ-ÇIKIŞ, 1500RPM 2,2KKW
- KROMAJLI VE KROMAJ SİZ ÜRETİLEBİLİR
- EMİŞLİDİR
- 2 YÖNE ÇALIŞABİLİR
- 4 BARA KADAR ÇALIŞABİLİR
- HIZ AYARLI (İNVERTÖRLÜ) ÜRETİLEBİLİR
- 3-4 TON/HOUR OIL PUMP. 1" OR 1 1/4" INLET-OUTLET, 1500RPM 1,1KW
- 9-10 TON/HOUR OIL PUMP, 1 1/2" INLET-OUTLET, 1500RPM 1,5KKW
- 12-14 TON/HOUR OIL PUMP, 2" INLET-OUTLET, 1500RPM 2,2KKW
- CAN BE PRODUCED AS CHROMATED OR MATT
- SELF PRIMING
- OPERATED BOTH DIRECTION
- OPERATABLE UPTO 4 BAR
- SPEED ADJUSTMENT



HER ÜRÜN İÇİN
POMPA TIPLERİ

PUMPS FOR
EVERY KIND OF
PRODUCT

- ÇEŞİTLİ TRANSFER POMPALARI
- VARIOUS TRANSFER PUMPS



G20-0,6



G20-0,8



10M OIL



14M OIL



25M OIL



30M OIL



50M OIL



20B

MODEL	KAPASİTE/CAPACITY	GÜÇ/POWER	MAMUL/PRODUCT	AĞIRLIK/WEIGHT
G20-06	900 lt/h	0,6 hp	Yağ / Oil	6 kg
G20-08	1700 lt/h	0,8 hp	Yağ / Oil	7 kg
10 OIL	300 lt/h	0,4 hp	Yağ / Oil	4 kg
14 OIL	600 lt/h	0,6 hp	Yağ / Oil	5 kg
25 OIL	1800 lt/h	0,9 hp	Yağ / Oil	8 kg
30 OIL	3000 lt/h	1,2 hp	Yağ / Oil	11 kg
50 OIL	11000 lt/h	3,0 hp	Yağ / Oil	22 kg

**KENDİNDEN EMİŞLİ
PASLANMAZ ÇELİK SANTRİFÜJ
POMPALAR
SELF PRIMING STAINLESS
STEEL CENTRIFUGAL PUMPS**

- JESXM5
- JES8



* ARABALI OLARAK
ÜRETİLEBİLİR /
WHEELBARROW
MODEL



JESX5



JES8



**CD-2CD Serisi Tek ve Çift
Kademeli Komple
Paslanmaz Çelik
CD-2CD**



**CDX-2CDX Serisi Tek ve
Çift Kademeli Komple
Paslanmaz Çelik
CDX-2CDX**



**DWC Serisi Tek
Kademeli Komple
Paslanmaz Çelik
DWC**



**DWO Serisi Açık Fanlı
Paslanmaz Çelik
DWO**



**Kendinden Emişli
Paslanmaz Çelik 4,5 m³/h
JESF**



**MATRIX Serisi Yatay
Milli Paslanmaz Çelik
MATRIX**

İMPELLER VE SANTRİFÜJ POMPA MODELLERİ

SP2 – 2000 LT/SAAT SANTRİFÜJ POMPA / CENTRIFUGAL PUMP
SP3 – 3000 LT/SAAT SANTRİFÜJ POMPA / CENTRIFUGAL PUMP
SP5 – 5000 LT/SAAT SANTRİFÜJ POMPA / CENTRIFUGAL PUMP
SP10 – 10000 LT/SAAT SANTRİFÜJ POMPA / CENTRIFUGAL PUMP
SP14 – 14000 LT/SAAT SANTRİFÜJ POMPA / CENTRIFUGAL PUMP
MG 25 – 2000 LT/SAAT NEOPREN FANLI POMPA / PUMP WITH NEOPRENE FAN
MG 50 – 5000 LT/SAAT NEOPREN FANLI POMPA / PUMP WITH NEOPRENE FAN
MG 150 – 10000 LT/SAAT NEOPREN FANLI POMPA / PUMP WITH NEOPRENE FAN
G20 0,6hp – 900 LT/SAAT DİŞLİ POMPA / GEAR PUMP
G20 0,8hp – 1700 LT/SAAT DİŞLİ POMPA / GEAR PUMP



EPMINI



EPMIDDEX



EPMAJOR



BY-PASS IMPELLER



EP MINOR



EP MINOR B - BYPASS

PERİSTALTİK POMPALAR – PERISTALTIC PUMPS

ZETA – PE 16
ZETA – PE 30
ZETA – PE 45
ZETA – PE 50
ZETA – PE 65



**TAM HAT BAL TESİSİ
İŞLEME & PAKETLEME
TOTAL HONEY PLANT
PROCESSING & PACKING**

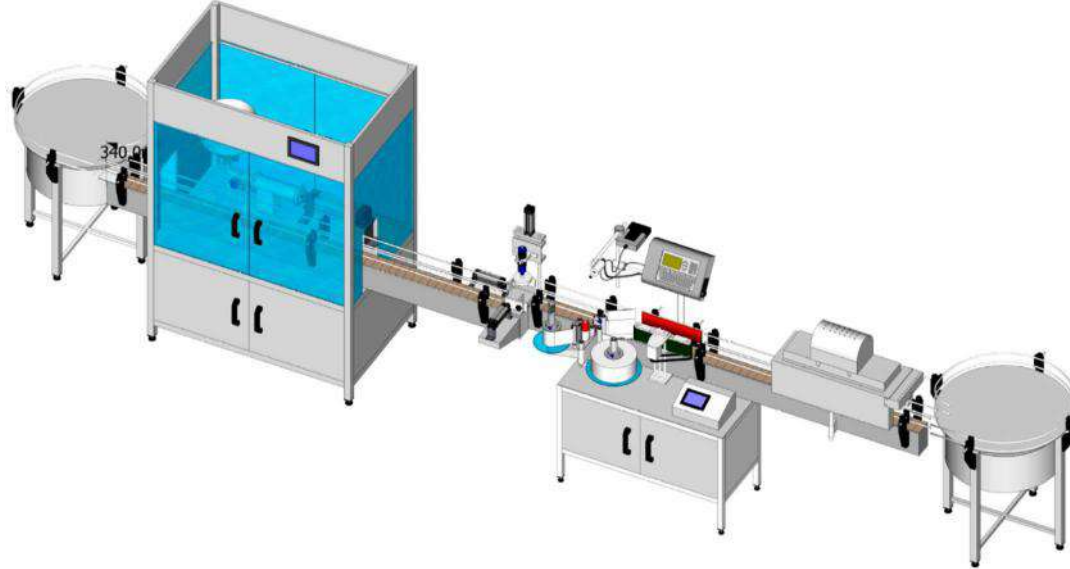



kahyaoglu

paslanmaz çelik san.tic.ltd.şti.

since 1997
**KAHYAOGLU
MARKET**



İZMİR YOLU TELLİKAVAK MEVKİİ NO:16 AYVALIK BALIKESİR TÜRKİYE

+90 266 312 73 74 – 75

www.kahyaoglupaslanmaz.com

www.kahyaoglupaslanmaz.net



<https://www.facebook.com/kahyaoglupaslanmaz>



<https://www.youtube.com/channel/UCzB-1GkVi6jIH7A2FituX4g>



<https://vimeo.com/user2162653>

